

APPROXIMATE WEIGHT IS: 618.77 lbs.

# - SELF-DUMPING STEEL HOPPER W/ BUMPER RELEASE - MODEL: D-100-HD

\*\*\* ANY ADDITIONS, DELETIONS, OR OMISSIONS MUST BE CORRECTED ON THIS DRAWING AS THIS DRAWING WILL BE CONSIDERED ALL INCLUSIVE \*\*\*  
 ALL GRAPHICS PROVIDED ARE FOR REFERENCE ONLY. IF CERTAIN DIMENSIONS ARE CRITICAL PLEASE VERIFY THOSE DIMENSIONS WITH YOUR SALESPERSON

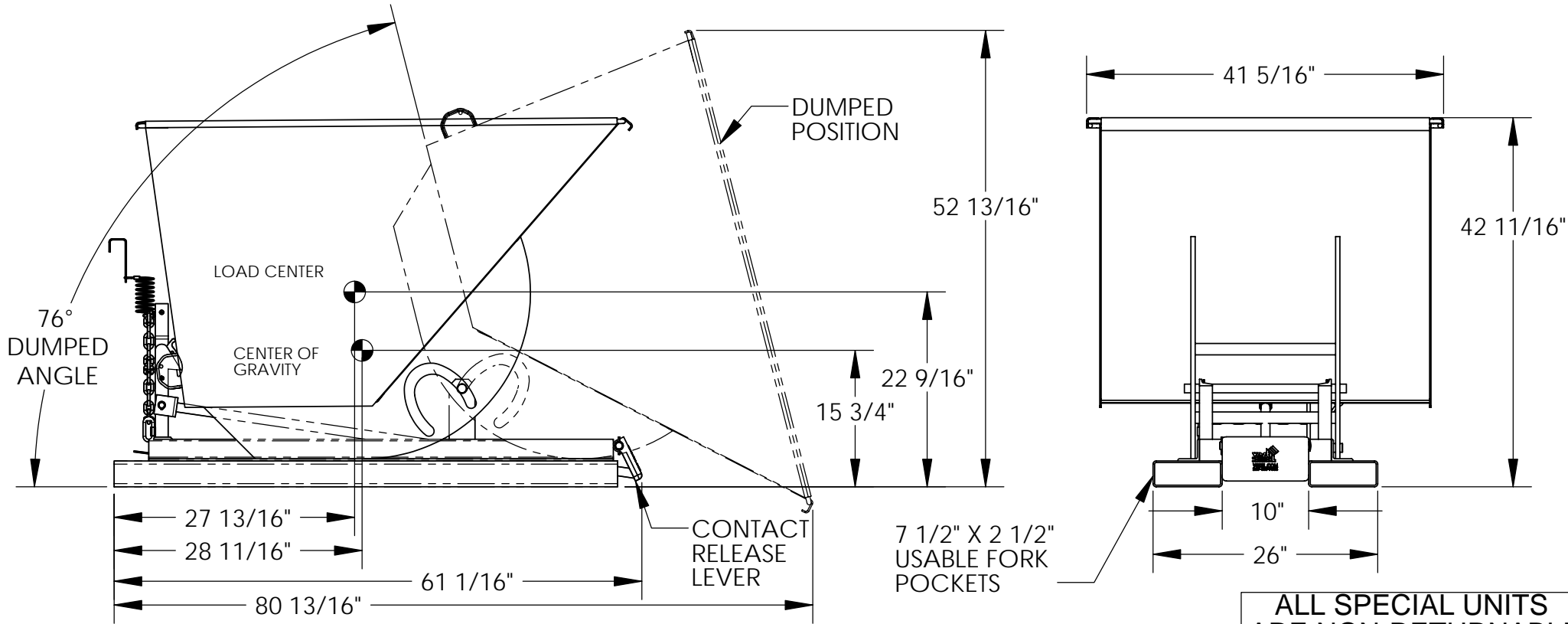

**ALL SPECIAL UNITS ARE NON-RETURNABLE**

## STANDARD FEATURES

VOLUME: 1 CU. YDS.  
 CAPACITY: 6,000 LBS.  
 OVERALL WIDTH: 41 5/16"  
 OVERALL LENGTH: 80 3/4"  
 OVERALL HEIGHT: 42 11/16"  
 RELEASE CABLE LENGTH: 48"  
 USABLE WORK ENVELOPE:  
 51 1/2"H X 80 1/4"L X 41 1/2"W

## SPECIAL FEATURES

NONE

\*\*\*WITH CASTER OPTION, THE MAXIMUM WEIGHT CAPACITY IS THE LOWEST WEIGHT CAPACITY OF EITHER THE HOPPER OR THE CASTERS\*\*\*

## OPTIONS

PLEASE CIRCLE ALL THAT APPLY

H - LEKP	D - LEKP
D - PLG	LUG
6 X 2 CASTER KIT ADDS 7 3/4" TO HEIGHT	8 X 2 CASTER KIT ADDS 9 3/4" TO HEIGHT
PLASTIC LID	

**APPROVAL**

I, the undersigned, hereby approve this print.  
 This includes my approval of design & dimensions

As drawn       As marked

Signed: \_\_\_\_\_ Date: \_\_\_\_\_

**LEAD TIME WILL START UPON RECEIPT OF SIGNED APPROVAL DRAWING**

DISTRIBUTOR'S NAME:

VESTIL MANUFACTURING

P.O.#

X

W.O.#

X

DRAWN BY:

W. STALEY

DATE:

5/7/08

SCALE: 1:17

SALES:

X

REFERENCE:

X

QUOTE #

X

FILE NAME:

37-007-012