

# HPT

## 50 & 55 Series

Hydraulic Hand Pallet Trucks

Operating instructions  
spare parts list  
service manual

Distributed by:  
Custom Equipment Company  
866-333-0728  
sales@custommhs.com  
www.custommhs.com

Model Number \_\_\_\_\_

Serial # \_\_\_\_\_

Date Placed in Service \_\_\_\_\_

**IMPORTANT: READ CAREFULLY  
BEFORE INSTALLING OR OPERATING LIFT**

Part orders are subject to a \$50 minimum charge.



# CONTENTS

Handle Assembly Instruction .....	6
FIGURE 1: LIFT EXPLODED VIEW (after September 2008) .....	7
TABLE 1: LIFT ITEMS (after September 2008) .....	8
FIGURE 2: LIFT EXPLODED VIEW (prior to September 2008) .....	9
TABLE 2: LIFT ITEMS (prior to September 2008) .....	10
FIGURE 3: PUMP AND HANDLE EXPLODED VIEW (prior to September 2008) .....	11
TABLE 3: PUMP AND HANDLE ITEMS (prior to September 2008) .....	12
Instructions .....	13
Service Manual .....	14
The Principle of Hydraulic Pump .....	15
Troubleshooting .....	16
1. Truck will not lift .....	16-17
2. Lift drops automatically .....	18
3. Lift will not drop .....	19
4. Truck is leaking .....	19
5. Wheel Problem .....	20
6. Change or Add Oil .....	20-21
Three Month Maintenance Schedule .....	22
ORDERING REPLACEMENT PARTS .....	22
RESTOCKING POLICY .....	23
WARRANTY .....	24

# Responsibility of Owners and Users

## **Inspection and Maintenance**

The device shall be inspected and maintained in proper working order in accordance with Presto's owner's manual.

## **Removal from Service**

Any device not in safe operating condition such as, but not limited to, excessive leakage, missing rollers, pins, or fasteners, any bent or cracked structural members, cut or frayed electric, hydraulic, or pneumatic lines, damaged or malfunctioning controls or safety devices, etc. shall be removed from service until it is repaired to the original manufacturer's standards.

## **Repairs**

All repairs shall be made by qualified personnel in conformance with Presto's instructions.

## **Operators**

Only trained personnel and authorized personnel shall be permitted to operate PowerStak.

## **Before Operation**

Before using the device, the operator shall have:

- Read and/or had explained, and understood, the manufacturer's operating instructions and safety rules.
- Inspected the device for proper operation and condition. Any suspect item shall be carefully examined and a determination made by a qualified person as to whether it constitutes a hazard. All items not in conformance with Presto's specification shall be corrected before further use of the PowerStak.

## **During Operation**

The device shall only be used in accordance with this owner's manual.

- Do not overload.
- Ensure that all safety devices are operational and in place.

## **Modifications or Alterations**

Modifications or alterations to any Presto industrial positioning equipment shall be made only with written permission from Presto.

# SAFETY ALERT SYMBOLS AND SIGNAL WORDS

The safety of all persons operating, maintaining, repairing, or in the vicinity of this equipment is of paramount concern. This is a powerful machine with moving parts, and is capable of causing personal injury if proper precautions are not taken. Therefore, throughout this manual, certain hazards have been identified which may occur in the use of the machine, and there are appropriate instructions or precautions which should be taken to avoid these hazards. In some cases, there are consequences which may occur if instructions or precautions are not followed. Below are the symbols and signal words along with their definitions referenced from ANSI Z535.4 - Product Safety Signs and Labels.

## Safety Alert Symbols

These are the safety alert symbols.. They are used to alert you to potential physical injury hazards. Obey all safety messages that follow this symbol to avoid possible injury or death.



**For use with DANGER signal word**  
(Red Background)



**For use with WARNING signal word**  
(Orange Background)



**For use with CAUTION signal word**  
(Yellow Background)

## Signal Words

The meaning of different signal words as defined by ANSI Standard Z535.4 indicates the relative seriousness of the hazardous situation.



(Red Background)

DANGER indicates a hazardous situation which, if not avoided, will result in death or serious injury.



(Orange Background)

WARNING indicates a hazardous situation which, if not avoided, could result in death or serious injury.



(Yellow Background)

CAUTION, used with the safety alert symbol, indicates a hazardous situation which, if not avoided, could result in minor or moderate injury.



(Blue Background)

NOTICE is used to address practices not related to personal injury.



(Green Background)

SAFETY INSTRUCTIONS (or equivalent) signs indicate safety-related instructions or procedures.

# Handle Assembly Instruction

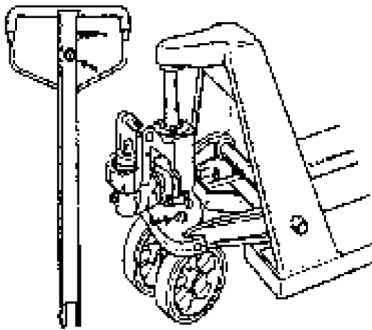

1. Make sure the symbol on the handle and pump are the same

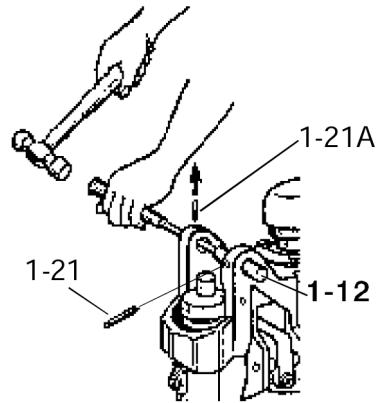

2. Take out screw (1-21)  
Hit out shaft (1012)

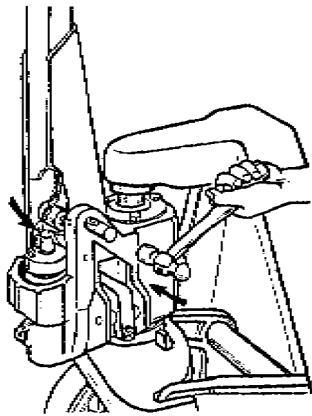

3. Put handle on pump body, then take out the chain from handle. Hit in shaft (1-12)

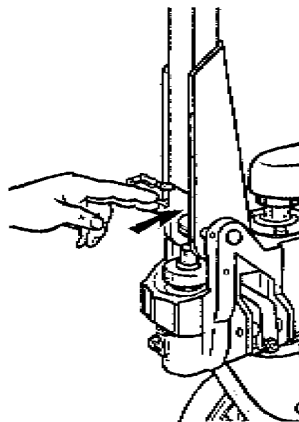

4. Insert chain through shaft (1-12)

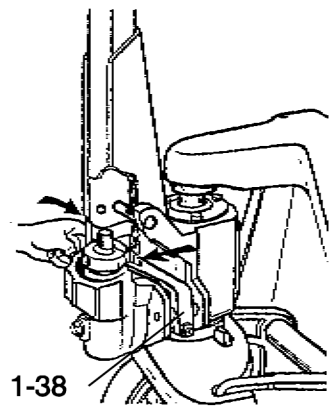

5. Connect chain with activator (1-38)

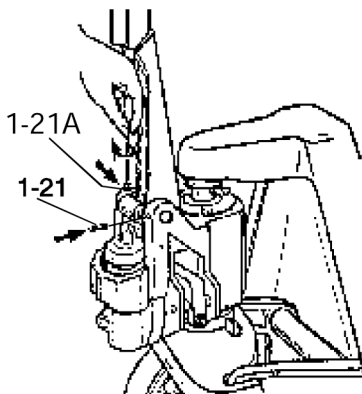

6. First, put spring pin (1-21) in pump. Then, put in screw (1-21)

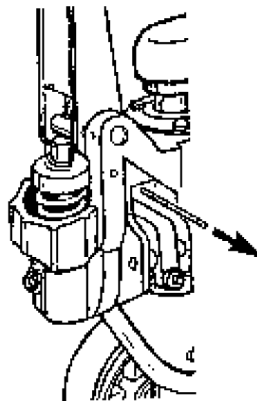

7. Take out steel axle from pump

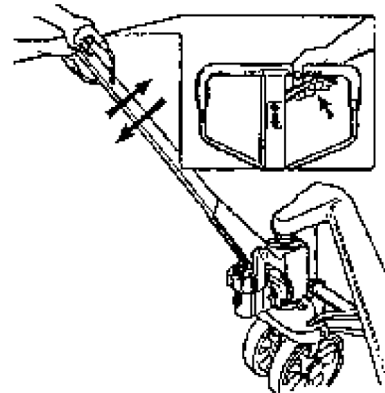

8. Depress pump handle about 10 times while keeping fingertip on "Lower Position" to release air from pump

After September 2008

Figure 1. Lift Exploded View

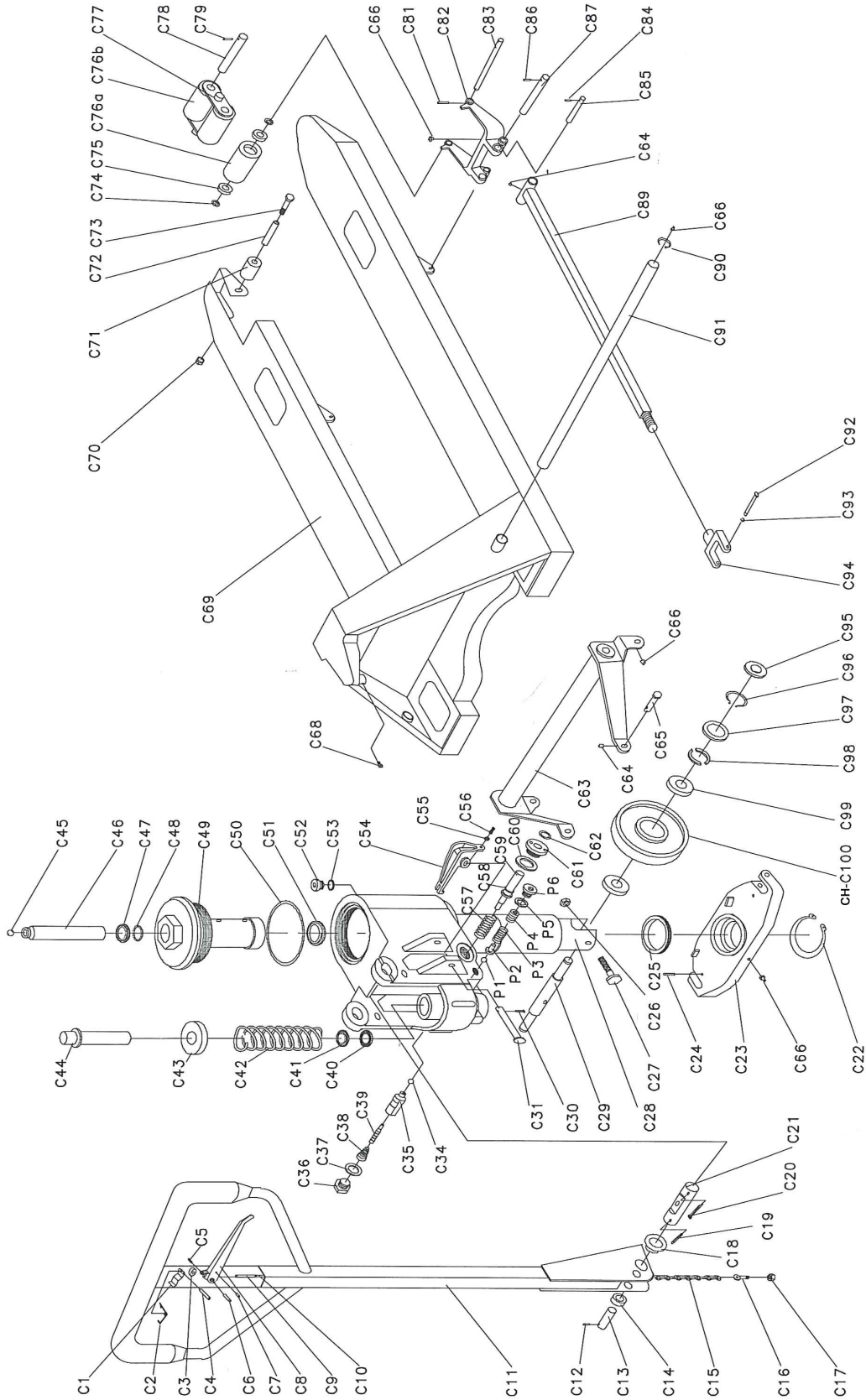

## After September 2008

### Table 1. Lift Items

No.	Description	Qty
C1	Spring	1
C2	Spring	1
C3	Roller	1
C4	Elastic Pin	1
C5	Elastic Pin	1
C6	Elastic Pin	1
C7	Elastic Pin	1
C8	Handle	1
C9	Join Blade	1
C10	Pull Rod	1
C11	Hand Tube	1
C12	Elastic Pin	1
C13	Pressure Roller Shaft	1
C14	Pressure Roller	1
C15	Chain	1
C16	Adjusting Screw	1
C17	Nut	1
C18	Bushing	1
C19	Elastic Pin	1
C20	Split Pin	1
C21	Pressure Shaft	1
C22	Retaining Ring for Axle	1
C23	Supporting Base	1
C24	Elastic Pin	2
C25	Bearing	1
C26	Nut	1
C27	Bolt	1
C28	Base Frame	1
C29	Shaft	1
C30	Retaining Ring for Axle	1
C31	Pin Lever	1
C34	Steel Bead	1
C35	Seat of Damping Valve	1
C36	Plug	1

No.	Description	Qty
C37	Copper Washer	1
C38	Spring	1
C39	Spindle of Damping	1
C40	U-Ring	1
C41	Dust Ring	1
C42	Spring	1
C43	Hood	1
C44	Small Piston Rod	1
C45	Steel Ball	1
C46	Big Piston Rod	1
C47	Dust Ring	1
C48	O-Ring	1
C49	Cylinder Liner	1
C50	O-Ring	1
C51	U-Ring	1
C52	Plug	1
C53	Copper Wash	1
C54	Lever Plate	1
C55	Nut	1
C56	Regulate Screw	1
C57	Spring	1
C58	O-Ring	1
C59	Valve Tappet	1
C60	Copper Washer	1
C61	Cupreous Sheath	1
C62	O-Ring	1
C63	Rocker Arm	1
C64	Oiler	4
C65	Pin	2
C66	Oiler	9
C68	Inside Hex Screw	1
C69	Fork Frame	1
C70	Nut	2
C71	Pilot Wheel	2

No.	Description	Qty
C72	Sheath	2
C73	Bolt	2
C74	Washer	4(8*)
C75	Bearing	4(8*)
C76a	Single Fork Wheel	2(0*)
C76b	Double Fork Wheel	0(4*)
C77	Nog of Fork Wheel	0(4*)
C78	Shaft for Double Wheel	0(4*)
C79	Elastic Pin	0(8*)
C81	Elastic Pin	2
C82	Frame of Fork Wheel	2
C83	Shaft of Fork Wheel	2
C84	Elastic Pin	2
C85	Short Shaft	2
C86	Elastic Pin	2
C87	Shaft	2
C89	Straight Tappet	2
C90	Elastic Pin	1
C91	Long Shaft	1
C92	Pin	2
C93	Retaining Ring for Axle	2
C94	Joint	2
C95	Dust Cover	2
C96	Retaining Ring for Axle	2
C97	Bowl Nut	2
C98	Half Circle	2
C99	Bearing	4
CH-C100	Steel Wheel	2
P1	Steel Ball	1
P2	Steel Ball Base	1
P3	Spring	1
P4	Screw	1
P5	Copper Washer	1
P6	Plug	1

Prior to September 2008

Figure 2. Lift Exploded View

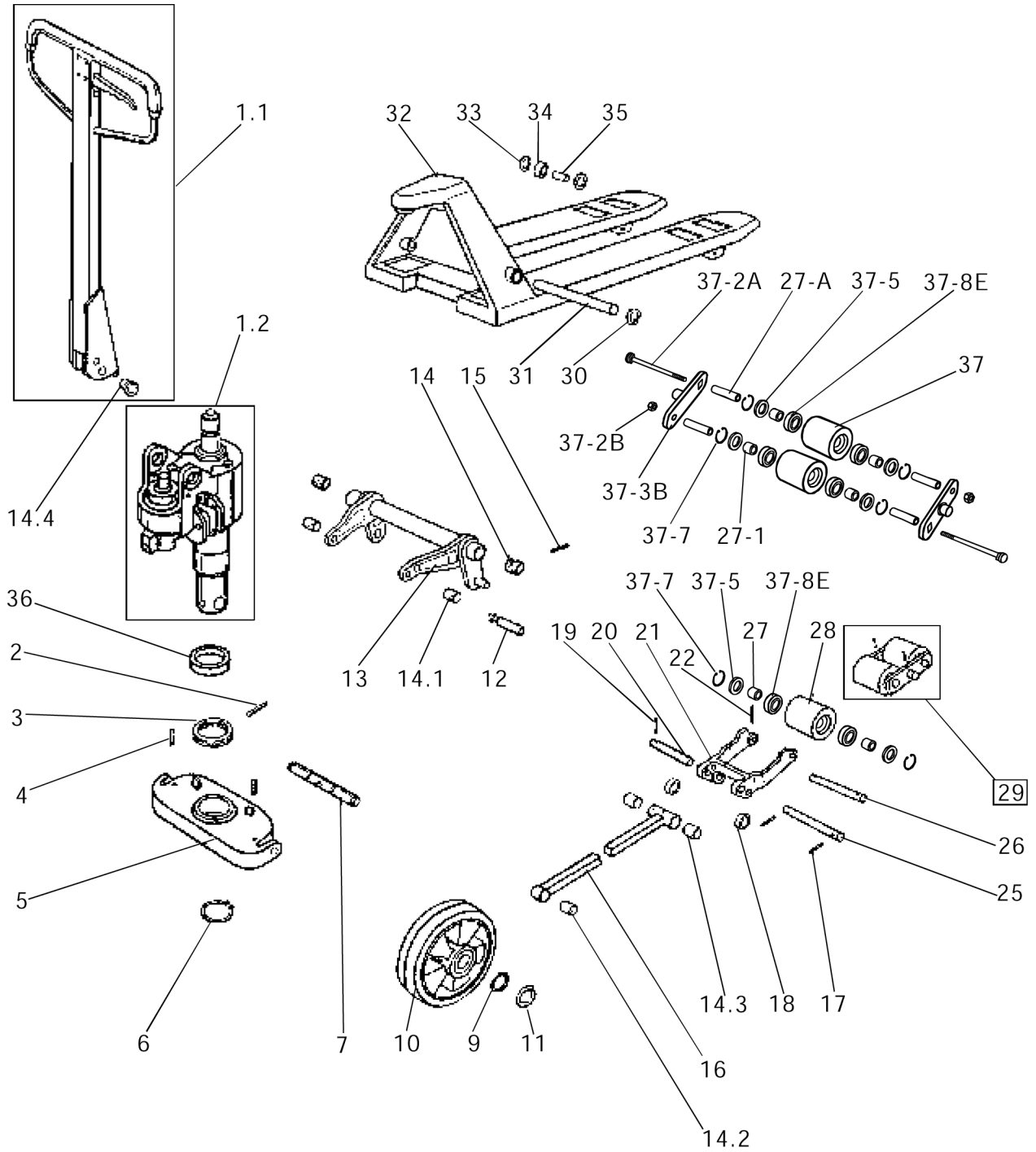

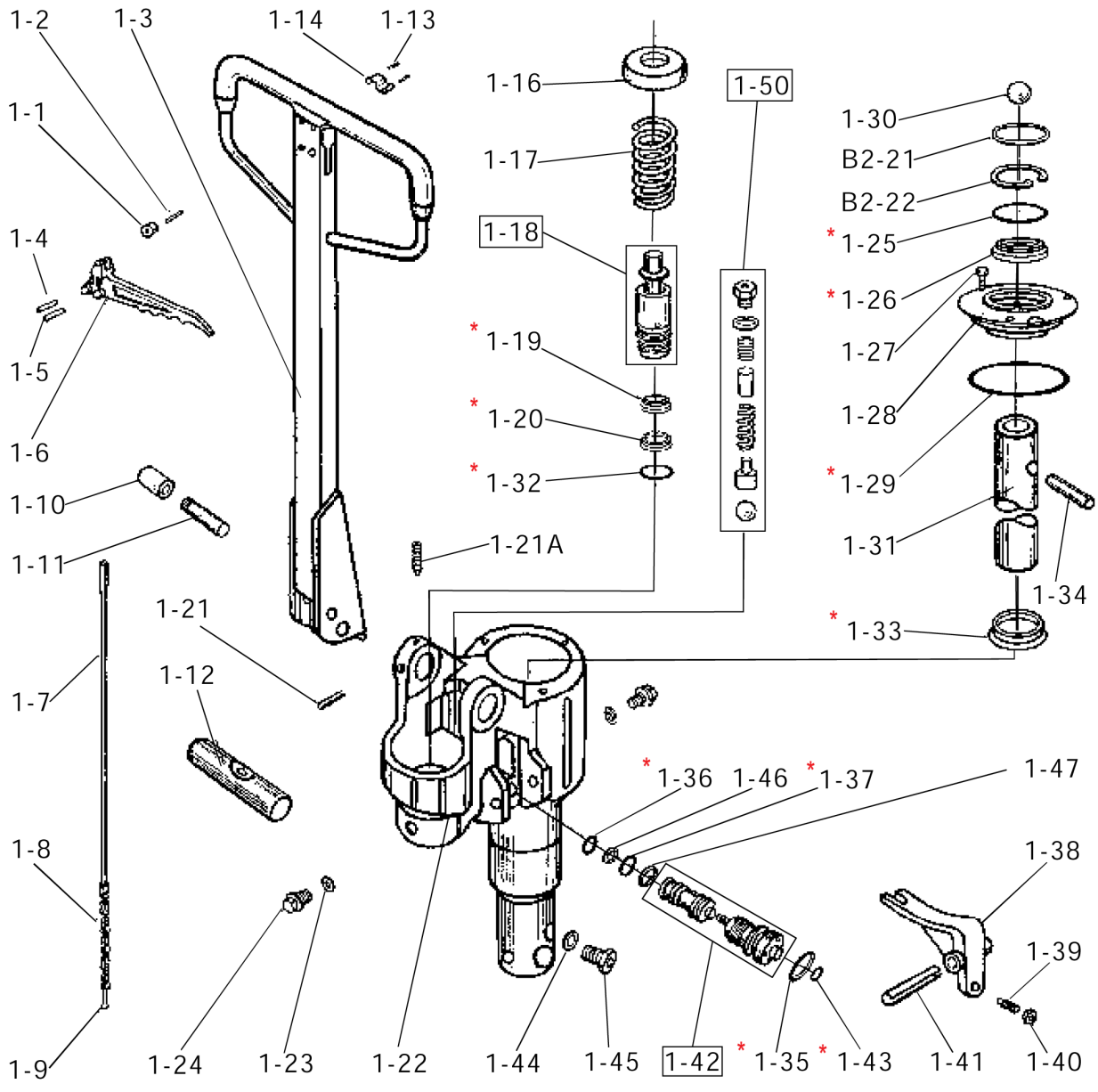

**Table 2. Lift Items**

<b>No.</b>	<b>Description</b>	<b>Qty</b>	<b>No.</b>	<b>Description</b>	<b>Qty</b>
1.1	Handle assy	1	20	Shaft	2
1.2	Pump assy.	1	21	Load wheel frame	2
2	Spring pin	2	22	Spring pin	2
3	Bearing	1	25	Shaft	2
4	Spring pin	2	26	Shaft	2
5	Pressure plate	1	28	Single load wheel assy.	
6	Circlip	1	37-8E	Bearing	6
7	Wheel shaft	1	27	Washer	2
9	Washer	2	37-5	Dust ring	6
10	Steering wheel assy.	2	37-7	Circlip	6
10.1	Nylon wheel	2	37	Load sheel	2
10.2	PU cover cast iron	2	27-1	Washer	4
10.3	Rubber cover aluminum	2	27-A	Bush	4
10.4	PU cover aluminum	2	37-3B	Wheel plate	2
11	Circlip	2	37-2B	Nut	2
12	Arm pin	2	37-2A	Shaft	2
13	Left arm	1	29	Tandem load wheel assy.	
14	Copper bush	2	30	Circlip	2
14.1	Copper bush	2	31	Long shaft	1
14.2	Copper bush	2	32	Fork body	1
14.3	Copper bush	4	33	Circlip	4
14.4	Copper bush	2	34	Entry roller	2
15	Spring pin	2	35	Shaft	2
16	Push pod	2	36	Cap of bearing	1
17	Spring pin	4			
18	Exit roller	4			
19	Spring pin	2			

Prior to September 2008

Figure 3. Pump and Handle Exploded View



Prior to September 2008

**Table 3. Pump and Handle Items**

<b>No.</b>	<b>Description</b>	<b>Qty</b>	<b>No.</b>	<b>Description</b>	<b>Qty</b>
1-1	Stop rubber	1	1-26	Seal UN32	1
1-2	Spring pin	1	1-27	Screw	1
1-3	Handle	1	1-28	Pump cap	1
1-4	Spring pin	1	1-29	O-ring P62	1
1-5	Spring pin	1	1-30	Ball	1
1-6	Lowering level (inger tip)	1	B2-21	Washer	1
1-7	Linkage	1	B2-22	Circlip	1
1-8	Chain	1	1-31	Cylinder	1
1-9	Chain rod	1	1-32	O-ring P31	1
1-10	Pressure roller	1	1-33	Seal UN32	1
1-11	Shaft	1	1-34	Pin	1
1-12	Shaft	1	1-35	O-ring	1
1-13	Spring pin	1	1-36	O-ring	1
1-14	Spring plate	1	1-37	O-ring	1
1-16	Spring cap	1	1-38	Activator	1
1-17	Spring	1	1-39	Bolt	1
1-18	Plunger assy.	1	1-40	Nut	1
1-19	Seal DH18	1	1-41	Spring pin	1
1-20	Seal DH18	1	1-42	Valve assy.	1
1-21	Screw	1	1-43	O-ring	1
1-21A	Spring pin	1	1-44	Washer	1
1-22	Pump body	1	1-45	Bolt	1
1-23	Washer	2	1-46	PU washer	1
1-24	Screw plug	2	1-47	PU washer	1
1-25	O-ring	1	1-50	Overload valve assy	1

## Instruction

### Raised Position

Depress the lever and pump handle until pallet has reached the desired height. A clearance of 1" between the floor and pallet is usually sufficient to move the load. Do not lift load with one fork or extremity of forks.

### Neutral Position

The neutral position is found between the raise and lower position. This neutral (drive) position disengages the lifting mechanism making the handle free from hydraulic resistance and becomes almost weightless, yet the forks retain their raised position. Always use the neutral position when moving a load.

### Lowered Position

Pull the lever up to lower the forks. The lever is spring loaded for lowering only, therefore when you release the lever it will automatically return to the neutral position.



*For safe operation of Hand Pallet Truck, please read the following instructions:*

1. Do not operate the Hand Pallet Truck unless you are familiar with it and have been trained and authorized to do so. Read all warnings and instructions in this manual and on the machine.
2. Do not operate the Hand Pallet Truck until you have checked its condition. Give special attention to the wheels, handle, forks, lift, and lower control. Do not operate damaged or faulty trucks. Do not attempt repairs unless you are trained and authorized to do so.
3. Operate Hand Pallet Trucks only from the designated operating position. Never place any part of your body in the lifting mechanism or under the

forks or load. Do not carry passengers.

4. Do not handle unstable or loosely stacked loads. Use special care when handling long, high, or wide loads to avoid losing the load, striking bystanders, or tipping the trucks.
5. Do not overload the truck. Check capacity plate for carrying capacity information. Overloading may cause truck to perform incorrectly.
6. The capacity of the Hand Pallet Truck assumes an evenly distributed load with the center of the load being at the halfway point of the length of the forks.
7. Make sure the length of the forks match the length of the pallet. Using a pallet truck where the forks are longer than the pallet will damage the truck if the pallet truck is pushed through the pallet and the forks are under a second pallet behind the one being lifted. When lowering the load, make sure the area beneath the pallet is clear.
8. Observe traffic regulations. Yield right of way to pedestrians. Stop at cross aisles.
9. Hand Pallet Trucks are for general operation on level, flat hard surfaces.
10. It is recommended that the operator wear security shoes when using the Hand Pallet Truck.

**Failure to follow these instructions may cause serious injury to the operator or others**

# HPT 50 & 55 Series

## Service Manual

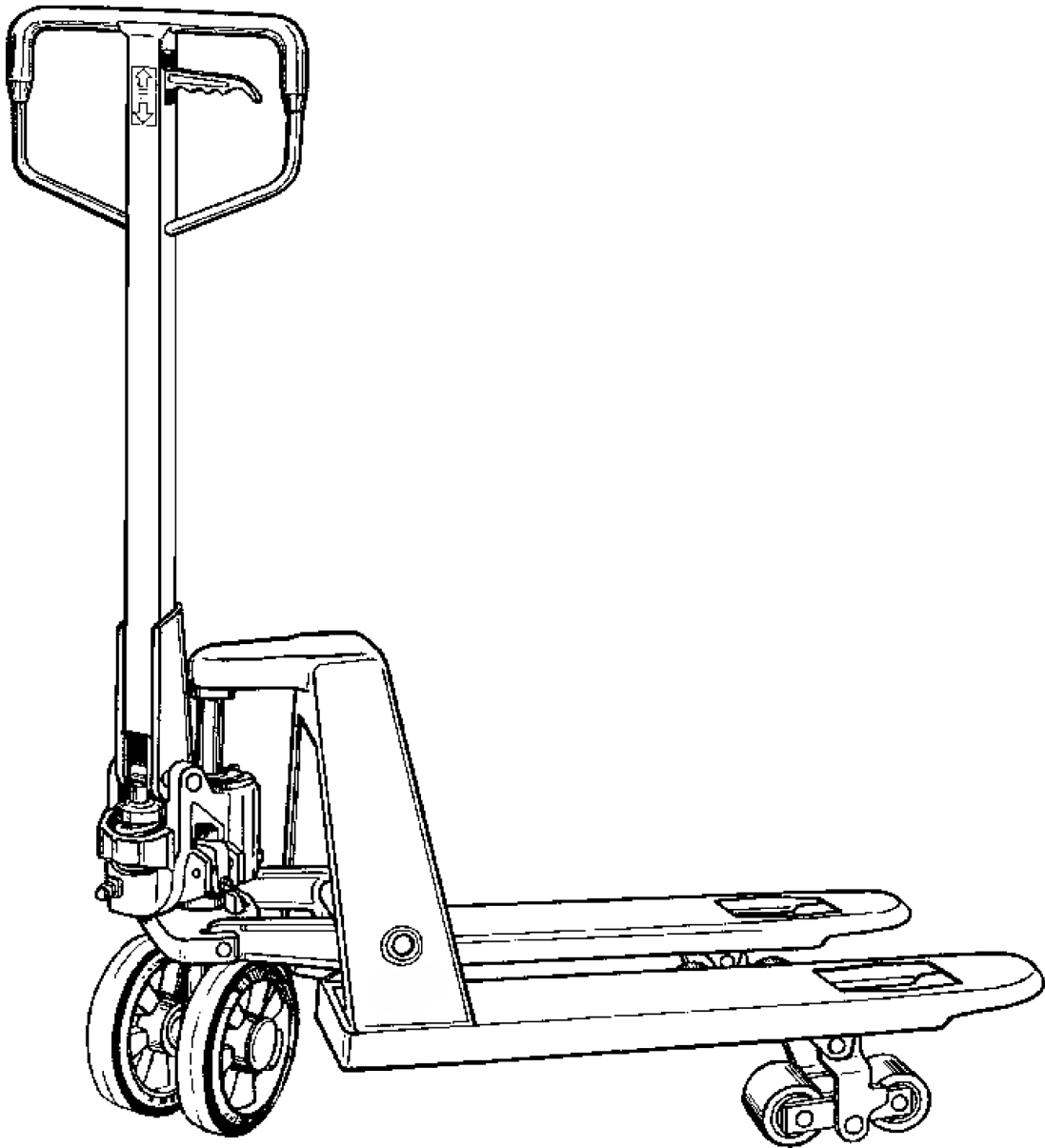

# The principle of hydraulic pump

(See figure 1-1)

## Lifting

1. Put finger tip (1-6) on Lifting Position; Lift handle, hydraulic oil flow from oil tank through channel A; Ball A open; Oil flow to piston through channel B.

2. Press handle; Ball A closed, Ball B open; Oil flow to cylinder from piston through channel B and channel C; Cylinder lifted; Truck lifted.

## Lower

1. Put finger tip (1-6) to Lowered Position

2. Part 1-39 move at D1 direction; Ball A and ball B open; Oil flow to oil tank from cylinder through channel C, ball B, and channel A.

## Transport

1. Put finger tip (1-6) to Neutral Position; Part 1-39 move at D1 direction; Ball A open.

2. Lift handle; Oil flow to piston from oil tank through channel A.

3. Press handle; Oil flow to oil tank from piston through channel B, ball A and channel A.

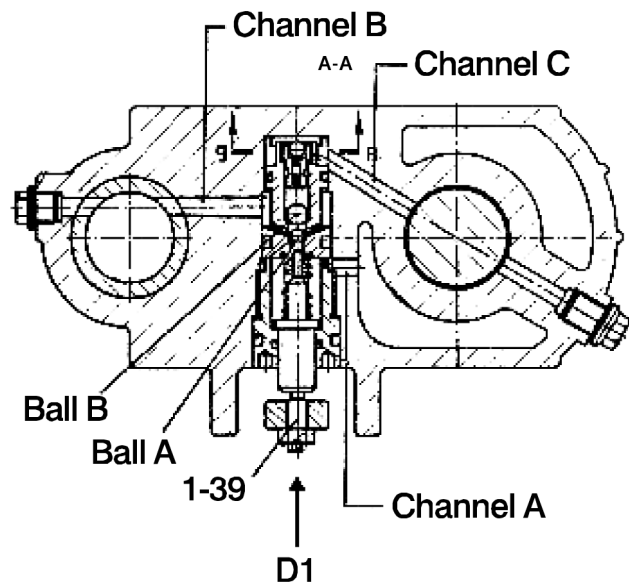
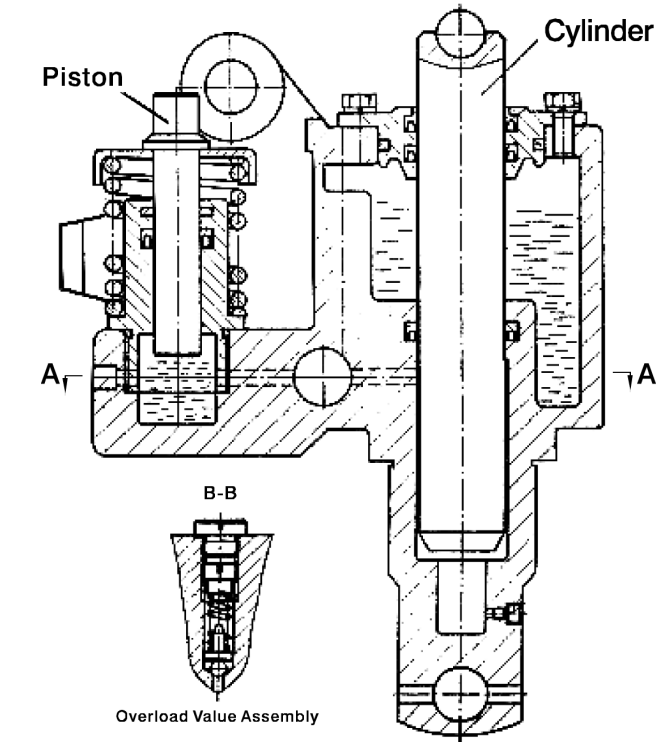

Figure 1-1. Cut-away pump diagram

# Troubleshooting

## 1. Truck will not lift

### 1.1: Release the air in pump

Put the finger tip to lower position. Pump handle about 10 times.

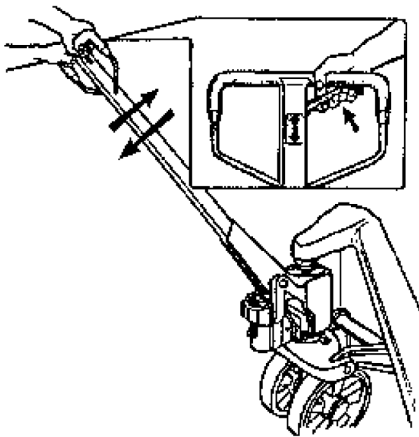

### 1.2: Check the chain (1-8)

Check chain (1-8), if it doesn't cross the shaft 1-12, please refit it.

### 1.3: Check symbol

Symbol on handle (1-3) and pump (1-5) must be the same.

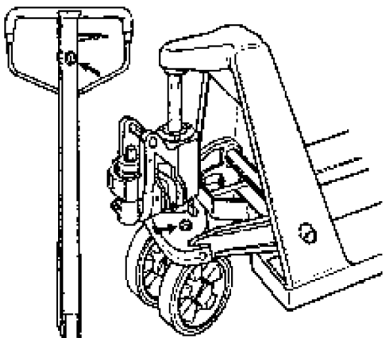

### 1.4a-c: Adjust the valve

#### 1.4a: Release screw (1-40)

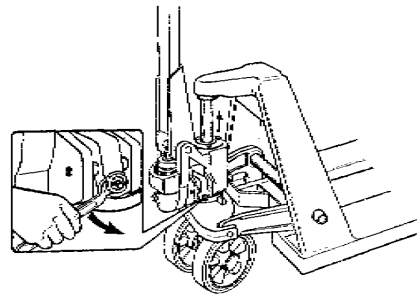

#### 1.4b: Screw nut

(1-39) in a circle circle along counterclockwise direction

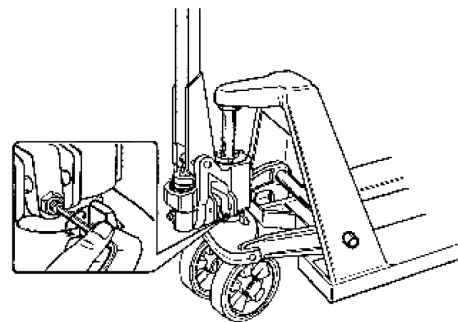

#### 1.4c: Check if it can be lifted

If it still does not lift, move to step 1.5.

If the truck lifts:

1. Lift the truck to the top position
2. Put the fingertip to 1.4c position; screw nut (1-39) counterclockwise until the Hand Pallet Truck starts to lower.
3. Screw 1-40

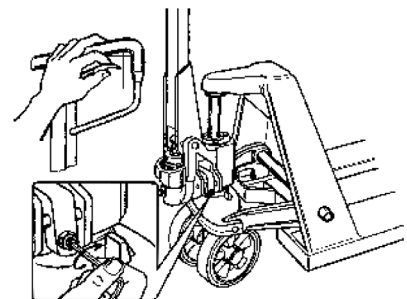

## 1.5a-e: Replace Valve Assembly (1-42)

1.5a: Place the truck on its side

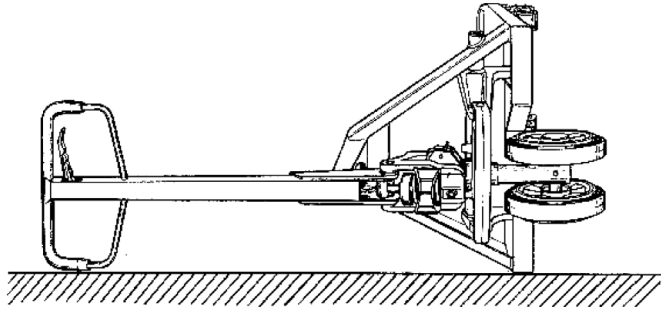

1.5b: Hit out spring pin (1-14) and take off lowering level (1-38)

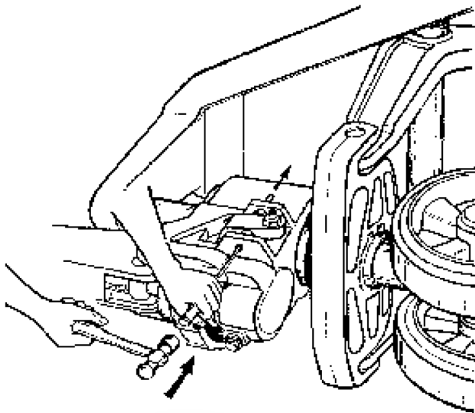

1.5c: Take the cylinder to the top position

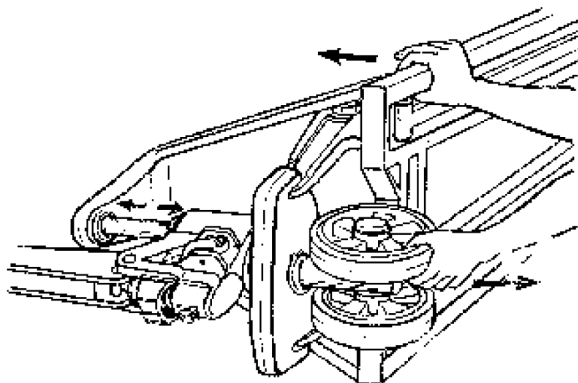

1.5d: Screw out copper brush of valve assembly (1-42)

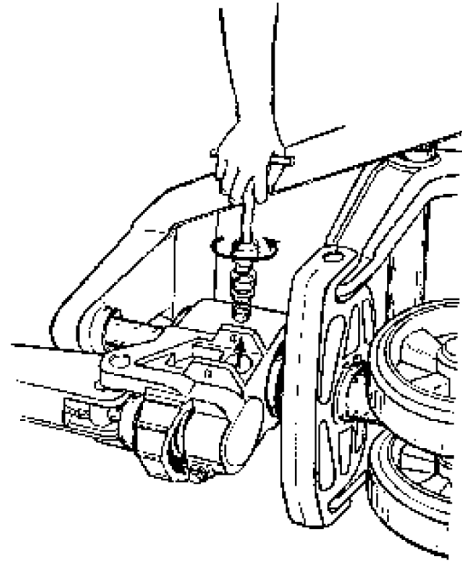

1.5e: Take out valve corn of valve assembly (1-42)

1. Install new valve assembly (1-42) including copper brush, valve.
2. Fit spring pin (1-38)
3. Repeat step 1.4

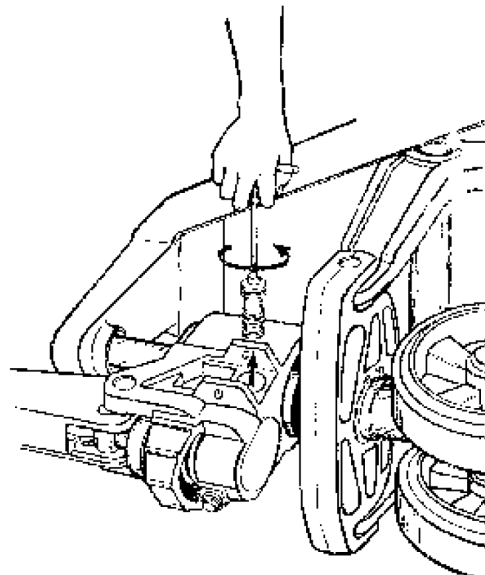



## **2. Lift drops automatically**

### **2.1a-h: Renew Seal (1-33)**

**2.1a: Take out circlip B2-22**

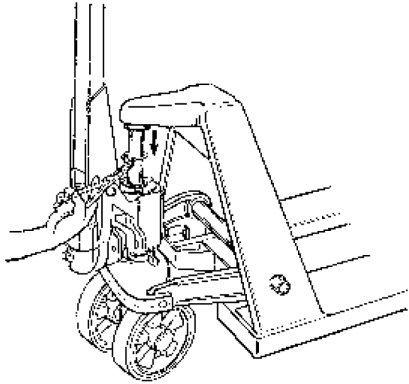

**2.1b: Screw off 1-27**

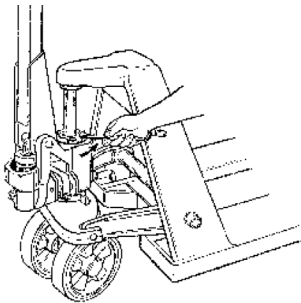

**2.1c: Take pump off from truck body**

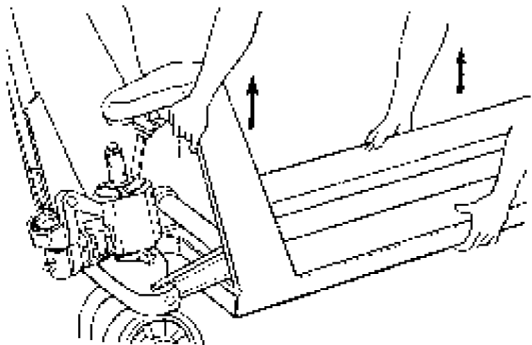

**2.1d: Take out piston cylinder (1-31)**

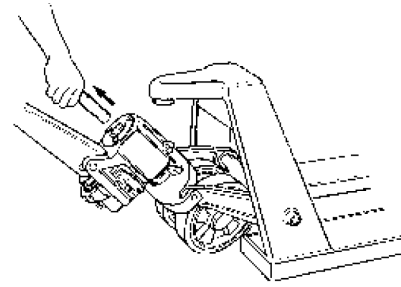

**2.1e: Take cap off pump**

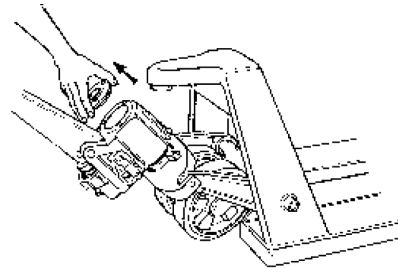

**2.1f: Pour out oil**

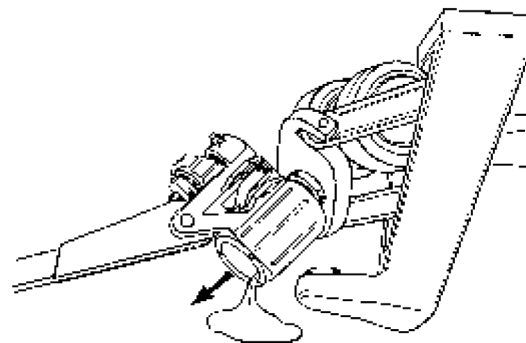

**2.1g: Renew Seal (1-33)**

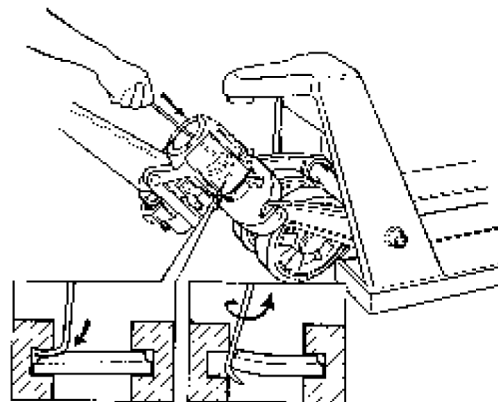

**2.1h: Pour in new oil**

### **3. Lift will not drop**

#### **3.1 Check the chain (1-8)**

1. Replace a broken chain
2. Check the shaft (1-12) and screw (1-21). Be sure the shaft (1-12) is fixed on pump body by screw (1-21). If shaft (1-12) is not fixed, the chain will be damaged by handle operation. If the chain and shaft have no problem, continue to step 3.2.

#### **3.2: Replace valve assembly (1-42)**

Refer to step 1.5

### **4. Pallet Truck is leaking**

#### **4.1a-b: Leak from piston**

4.1a: Take out 1-17

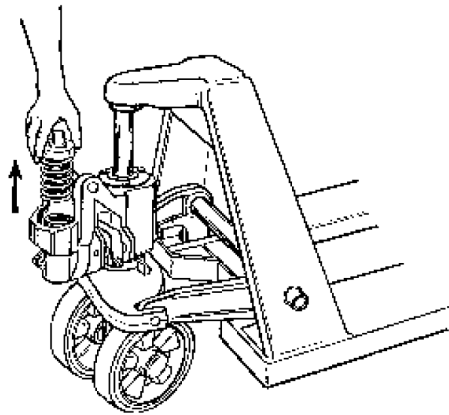

4.1b: Renew seal 1-19 & 1-20

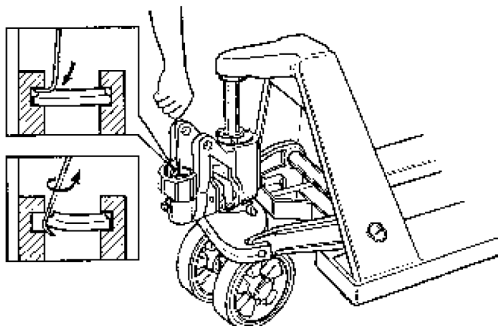

#### **4.2a-c: Leak from piston carriage**

4.2a: Take out 1-17

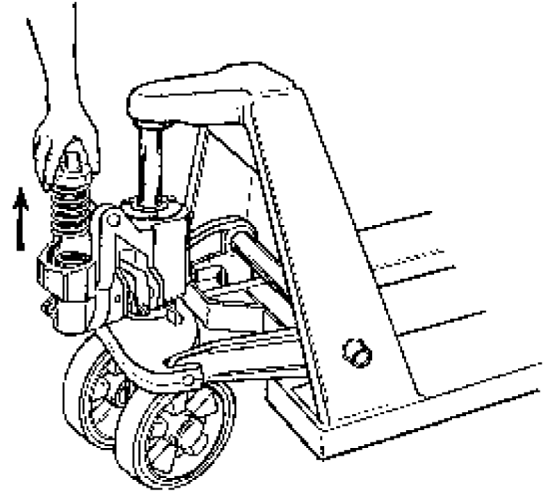

4.2b: Take out 1-18

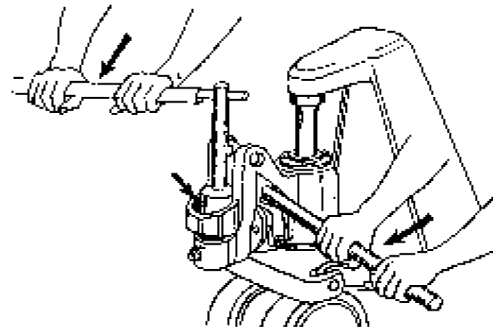

4.2c: Renew seal 1-32

## **5. Wheel problem**

### **5.1a-c: Problem of steering wheel**

**5.1a: Take off the wheel cap**

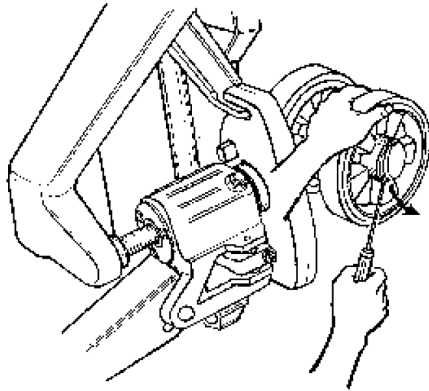

**5.1b: Take out circlip 11**

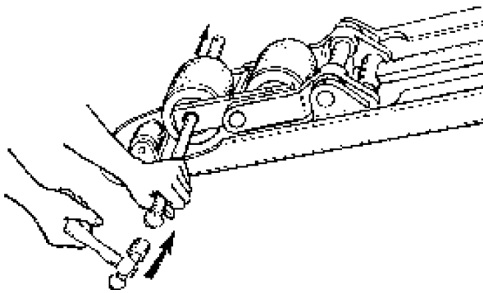

**5.1c: Change steering wheel**

### **5.2a-c: Change load wheel**

**5.2a: Take out spring pin 22 & 23 & 24**

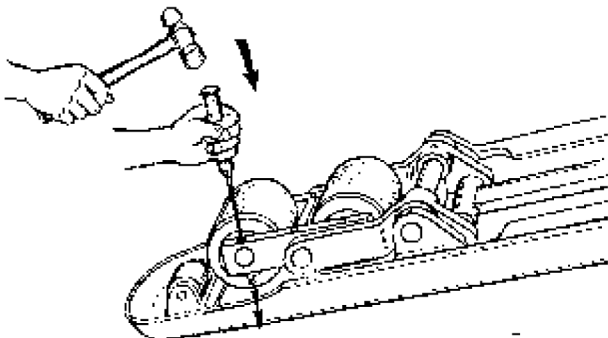

**5.2b: Hit out shaft**

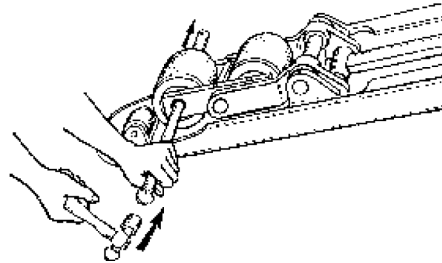

**5.2c: Change load wheel**

## **6. Change or add oil**

### **6.1a-g: Change oil**

**6.1a: Take out circlip B22-2**

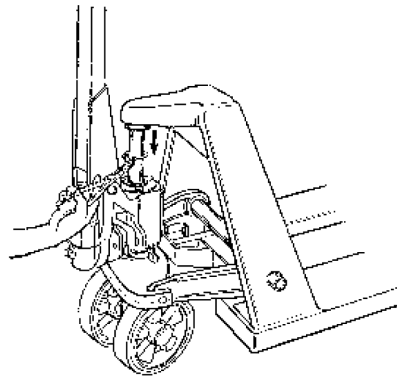

**6.1b Screw off 1-27**

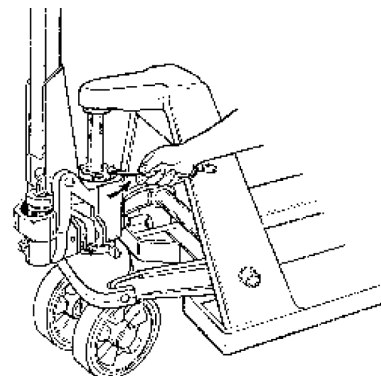

**6.1c: Take pump off of truck body**

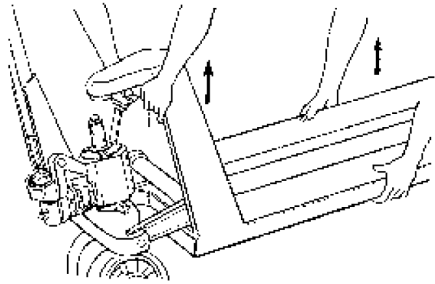

**6.1d: Take out piston cylinder**

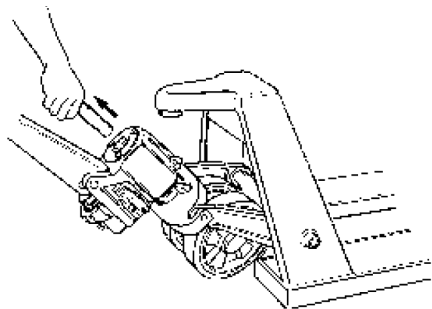

**6.1e: Take cap off of pump**

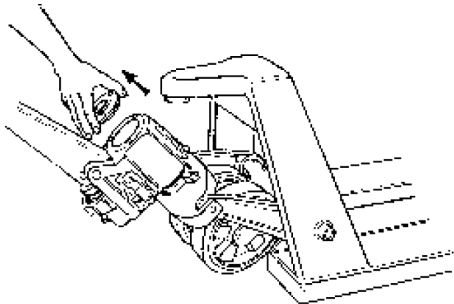

**6.1f: Pour out oil**

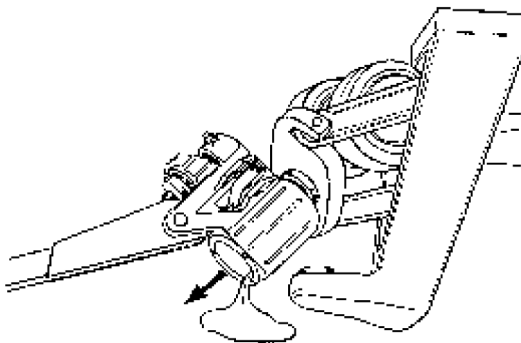

**6.1g: Pour in new oil**

**6.2a-b: Add oil**

**6.2a: Unscrew 1-27**

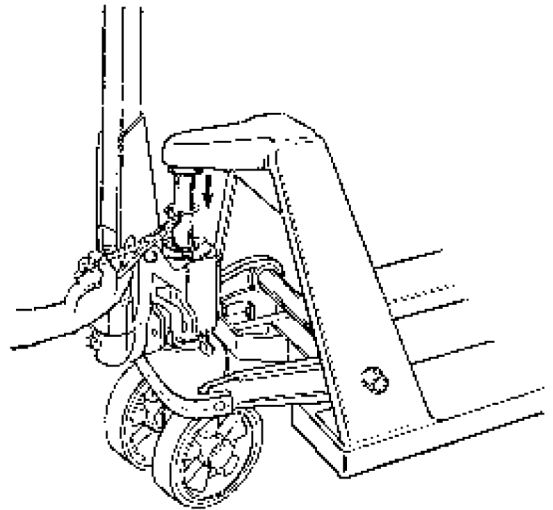

**6.2b: Add oil**

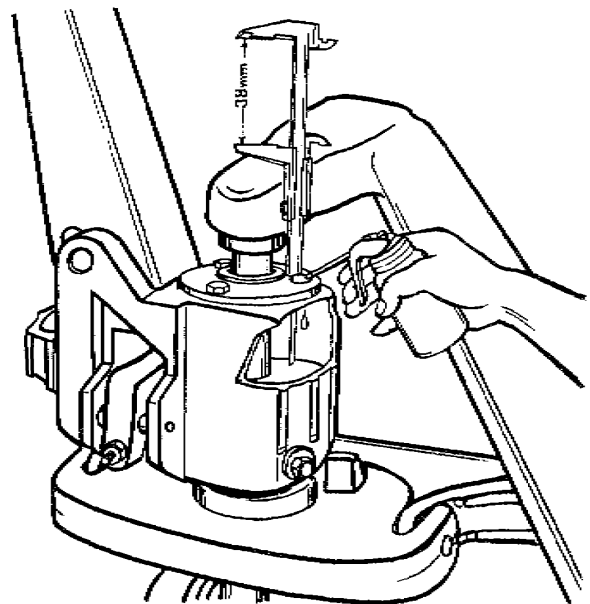

## Three month maintenance schedule

1. Check oil level
2. Lubricate joints, pins, axles, pushrods, steering wheel bearings with good molybdenum type grease.

### Ordering Replacement Parts

Presto Lifts has carefully chosen the components in your unit to be the best available for the purpose. Replacement parts should be identical to the original equipment. Presto Lifts will not be responsible for equipment failures resulting from the use of incorrect replacement parts or from unauthorized modifications to the unit.

Presto Lifts can supply all replacement parts for your lift. With your order, please include the model number and the serial number of the unit. You can find these numbers on the name plate. This plate is located within the scissors mechanism.

To order replacement parts, please call the Presto Parts Department. Parts are shipped subject to the following terms:

- FOB factory
- Returns only with the approval of our parts department.
- Credit cards preferred (except parts covered by warranty).
- Freight collect for truck (except parts covered by warranty).
- Freight – prepaid and invoice for small parcel shipments (except parts covered by warranty).

Parts replaced under warranty are on a “charge-credit” basis. We will invoice you when we ship the replacement part, then credit you when you return the worn or damaged part, and we verify that it is covered by our warranty. Labor is not covered under warranty for Parts orders.

#### **Presto Parts Department**

50 Commerce Way  
Norton, MA 02766

Telephone: 800-343-9322  
FAX: 888-788-6496  
Email: [service@PrestoLifts.com](mailto:service@PrestoLifts.com)  
**[www.PrestoLifts.com](http://www.PrestoLifts.com)**

## **PARTS**

Standard parts may be returned with a 20% restocking fee. Modified or custom-engineered parts are not returnable. Unfortunately, due to potentially concealed damage, all sales of electrical assemblies are final.

## **QUALITY ISSUES**

Should you feel there is a quality problem, please contact the seller to ask questions and gather information on how to rectify the issue. Presto Lift Inc. reserves the right to determine potential credits, as a result of factory defects, based on its inspection of the merchandise.

## **GENERAL**

All products shipped from our factory have passed Quality Assurance inspection and testing. The carrier of choice has signed for, and accepted the product in new working condition. The customer should inspect to ensure it is not received damaged, has no concealed damage or is not incomplete. Parts orders are determined to be complete based upon Presto Lift, Inc. inspection sheets and carrier shipping weights.

# Presto Lifts Limited Warranty Policy

Presto Lifts warrants all of its products against defects in the welded structural frame and, if applicable, scissor legs from faulty material and workmanship for a one (1) year period from the date of invoice date

All other components have a limited warranty against defects in faulty material and workmanship for a one (1) year period from the date of invoice date of invoice and 30 day limited warranty on labor. Please note that prior authorization from Presto Lifts is required on all warranty work.

There are no implied warranties of any kind, more specifically, there are no warranties of merchantability or fitness for any particular purpose. Presto Lifts' sole warranty shall be as set forth in this limited warranty.

Presto Lifts will elect to repair or replace a defective component without charge, if any components should become defective within the limited warranty period. Proof of purchase is required for warranty. The charge for shipping the defective component is the responsibility of the buyer and must be accompanied with an RGA number. The shipping charge to return the component to the buyer is the responsibility of Presto Lifts, Inc.

This limited warranty does not cover labor expense for removal or reinstallation of components after thirty days. This limited warranty shall not cover, among other things: damages resulting from foreign matter or water, failure to provide reasonable and necessary maintenance, and if applicable, use of product while charger is plugged into an AC outlet, or failure to follow operating instructions. The limited warranty is not valid for damage resulting from negligence, accident, unreasonable use, abuse or misuse, exceeding data plate capacities or altering the product without Presto Lifts authorization.

Presto Lifts expressly disclaims and excludes any liability for consequential, incidental, indirect or punitive damages or financial loss to people or property resulting from any breach of warranty or the operation or failure of this product.

Presto Lifts makes no representation that this product complies with local, state, or federal safety/product standards codes. Should this product fail to comply in any way with those codes, it shall not be considered a defect of materials or workmanship. Presto Lifts shall not be held liable for any damages resulting from noncompliance. It is the dealer's responsibility to exercise this limited warranty. This limited warranty is provided to the original purchaser (defined as the original end user) and is nontransferable. This constitutes the complete and final agreement involving Presto Lifts and limited warranty obligations for products.