

# TT & WT Tilt Tables

## Installation, Operation and Service Manual

Distributed by:  
Custom Equipment Company  
866-333-0728  
sales@custommhs.com  
www.custommhs.com

Model Number \_\_\_\_\_

Serial # \_\_\_\_\_

Date Placed in Service \_\_\_\_\_

**IMPORTANT: READ CAREFULLY  
BEFORE INSTALLING OR OPERATING LIFT**

Part orders are subject to a \$50 minimum charge.



# Presto Lifts Limited Warranty Policy

Presto Lifts warrants all of its products against defects in the welded structural frame and, if applicable, scissor legs from faulty material and workmanship for a period of five (5) years from the date of invoice.

All other components have a limited warranty against defects in faulty material and workmanship for a two (2) year period from the date of invoice and 30 day limited warranty on labor. Please note that prior authorization from Presto Lifts is required on all warranty work.

There are no implied warranties of any kind, more specifically, there are no warranties of merchantability or fitness for any particular purpose. Presto Lifts' sole warranty shall be as set forth in this limited warranty.

Presto Lifts will elect to repair or replace a defective component without charge, if any components should become defective within the limited warranty period. Proof of purchase is required for warranty. The charge for shipping the defective component is the responsibility of the buyer and must be accompanied with an RGA number. The shipping charge to return the component to the buyer is the responsibility of Presto Lifts, Inc.

This limited warranty does not cover labor expense for removal or reinstallation of components after thirty days. This limited warranty shall not cover, among other things: damages resulting from foreign matter or water, failure to provide reasonable and necessary maintenance, and if applicable, use of product while charger is plugged into an AC outlet, or failure to follow operating instructions. The limited warranty is not valid for damage resulting from negligence, accident, unreasonable use, abuse or misuse, exceeding data plate capacities or altering the product without Presto Lifts authorization.

Presto Lifts expressly disclaims and excludes any liability for consequential, incidental, indirect or punitive damages or financial loss to people or property resulting from any breach of warranty or the operation or failure of this product.

Presto Lifts makes no representation that this product complies with local, state, or federal safety/product standards codes. Should this product fail to comply in any way with those codes, it shall not be considered a defect of materials or workmanship. Presto Lifts shall not be held liable for any damages resulting from noncompliance. It is the dealer's responsibility to exercise this limited warranty. This limited warranty is provided to the original purchaser (defined as the original end user) and is nontransferable. This constitutes the complete and final agreement involving Presto Lifts and limited warranty obligations for products.

# CONTENTS

WARRANTY .....	3
<b>SECTION 1: Introduction</b> .....	5
Responsibility of Owners and Users.....	6
Safety Alert Symbols and Signal Words .....	7
<b>SECTION 2: Safety</b> .....	8
<b>SECTION 3: Installation</b> .....	10
A. Inspection	
B. Installing	
C. Electricals	
D. Hydraulics	
E. Testing the Tilter with No Load	
<b>SECTION 4: Operation</b> .....	11
A. Method of Operation	
B. Operation Procedures	
<b>SECTION 5: Maintenance</b> .....	12
A. Routine Inspection and Maintenance	
B. Chocking/Securing Procedures	
C. Troubleshooting Maintenance	
<b>SECTION 6: Service</b> .....	14
A. Replacing Cylinder Seals	
B. Ordering Replacement Parts	
ORDERING REPLACEMENT PARTS .....	22
RESTOCKING POLICY .....	23
RETURN GOODS AUTHORIZATION POLICY .....	24
<b>LIST OF FIGURES &amp; TABLES:</b>	
Figure 1 Hydraulic Schematic .....	15
Figure 2 Hydraulic Power Unit Wiring Diagram.....	15
Figure 3 Electrical Schematic Pump Unit Single Phase 115 Volts AC.....	16
Figure 4 Electrical Schematic Pump Unit 1 Phase 208, 240 Volts AC .....	17
Figure 5 TT Series Lightweight Tilt Specifications .....	18
Figure 6 WT Series Wide Base Tilt Specifications .....	19
Table 1 Hydraulic Oil Specifications .....	20
Figure 7 Labels and Locations.....	21

## **SECTION 1**

# **INTRODUCTION**

The TT & WT Series Lifts are tilters and are designed for lifting, tilting and positioning a wide variety of loads. These tilters are capable of being mounted on other Presto tables and stands or lagged directly to the floor. These lifts are designed for in-plant/non-hazardous location use only.

This manual provides all the information for the safe and proper installation, operation and maintenance of these tilters. It is important that this manual be read by all personnel involved with the installation, maintenance or operation of the tilter. Where unique situations arise, which are not covered in this manual, call Presto Lifts, Inc. for further instructions. Additional manuals are available upon request at [www.PrestoLifts.com](http://www.PrestoLifts.com).

The tilter has a nameplate which provides the load capacity ratings, serial number and model identification. Please refer to these numbers when ordering parts or requesting further information.

## **Responsibility of Owners and Users**

### **Inspection and Maintenance**

The device shall be inspected and maintained in proper working order in accordance with Presto's owner's manual.

### **Removal from Service**

Any device not in safe operating condition such as, but not limited to, excessive leakage, missing rollers, pins, or fasteners, any bent or cracked structural members, cut or frayed electric, hydraulic, or pneumatic lines, damaged or malfunctioning controls or safety devices, etc. shall be removed from service until it is repaired to the original manufacturer's standards.

### **Repairs**

All repairs shall be made by qualified personnel in conformance with Presto's instructions.

### **Operators**

Only trained personnel and authorized personnel shall be permitted to operate PowerStak.

### **Before Operation**

Before using the device, the operator shall have:

- Read and/or had explained, and understood, the manufacturer's operating instructions and safety rules.
- Inspected the device for proper operation and condition. Any suspect item shall be carefully examined and a determination made by a qualified person as to whether it constitutes a hazard. All items not in conformance with Presto's specification shall be corrected before further use of the PowerStak.

### **During Operation**

The device shall only be used in accordance with this owner's manual.

- Do not overload.
- Ensure that all safety devices are operational and in place.

### **Modifications or Alterations**

Modifications or alterations to any Presto industrial positioning equipment shall be made only with written permission from Presto.

# SAFETY ALERT SYMBOLS AND SIGNAL WORDS

The safety of all persons operating, maintaining, repairing, or in the vicinity of this equipment is of paramount concern. This is a powerful machine with moving parts, and is capable of causing personal injury if proper precautions are not taken. Therefore, throughout this manual, certain hazards have been identified which may occur in the use of the machine, and there are appropriate instructions or precautions which should be taken to avoid these hazards. In some cases, there are consequences which may occur if instructions or precautions are not followed. Below are the symbols and signal words along with their definitions referenced from ANSI Z535.4 - Product Safety Signs and Labels.

## Safety Alert Symbols

These are the safety alert symbols.. They are used to alert you to potential physical injury hazards. Obey all safety messages that follow this symbol to avoid possible injury or death.



**For use with DANGER signal word**  
(Red Background)



**For use with WARNING signal word**  
(Orange Background)



**For use with CAUTION signal word**  
(Yellow Background)

## Signal Words

The meaning of different signal words as defined by ANSI Standard Z535.4 indicates the relative seriousness of the hazardous situation.



(Red Background)

DANGER indicates a hazardous situation which, if not avoided, will result in death or serious injury.



(Orange Background)

WARNING indicates a hazardous situation which, if not avoided, could result in death or serious injury.



(Yellow Background)

CAUTION, used with the safety alert symbol, indicates a hazardous situation which, if not avoided, could result in minor or moderate injury.



(Blue Background)

NOTICE is used to address practices not related to personal injury.



(Green Background)

SAFETY INSTRUCTIONS (or equivalent) signs indicate safety-related instructions or procedures.


## **SECTION 2**


### **SAFETY**


The TT & WT Tilters are very powerful tilters capable of doing large amounts of work. They contain platforms which are hydraulically actuated and are capable of causing serious injury or damage if adequate precautions are not taken. **DO NOT INSTALL OR OPERATE THIS TILTER WITHOUT CAREFULLY READING THIS MANUAL.** Presto Lifts, Inc. has identified certain hazards which may occur during the installation, maintenance and use of these lifts.

For safety reasons, the tilters are provided with safety devices for use during maintenance and servicing. If performed properly, this will greatly reduce the possibility of injury.

The following system has been established for identification of potentially unsafe conditions or practices and is used throughout this manual.

 **DANGER** – Immediate hazard that will result in severe personal injury or death.

 **WARNING** – Hazard or unsafe practice that could result in severe personal injury or death.

 **CAUTION** – Hazard or unsafe practice that could result in minor personal injury or property damage.

**In the interest of safety, please read the entire manual carefully. You must understand the material in this manual before you install, use, or service the unit. If you have any question about any of the instructions in this manual, please contact Presto Lifts Inc. at 1-800-343-9322.**

**⚠WARNING**

**Do not perform any repair work on a lift in a fully extended position. Unload lift prior to working under or around.**

**All personnel must stand clear of the lift when the lift is in motion.**

**Do not put hands or feet under lift.**

**Do not work under lift without securing it first with proper maintenance devices.**

**Do not stand, sit or climb on the lift at any time.**

**Do not use the lift on soft, uneven or unstable surfaces.**

**Do not exceed the load capacity rating on the data plate.**

**Do not place a load on a moving lift.**

**Place a load in the center of the lift and be sure that the load is secured properly.**



## **SECTION 3**

# **INSTALLATION**

### **A. INSPECTION:**

Upon receipt of the tilters, inspect the equipment completely to determine if there is any shipment damage and that the tilter is complete. *Do not* use the tilter if there appears to be any damage. With the tilter in a collapsed position, check the following:

1. Check for signs of damage, especially to the electricals and hydraulics.
2. Check all connections for tightness. Also check for visible hydraulic liquid around the connections.
3. Check for any physical damage to the frame.
4. Inspect the platform for damage, either twisted or bent.

### **B. INSTALLING:**

Read all of the instructions prior to starting or connecting the tilter.

#### **1. Working Area**

- a) Make sure that the floor and the operation area is flat, stable, relatively smooth and free from dirt, obstacles and surface defects.
- b) Place the empty tilter in the exact operating area to be sure that there are no encumbrances due to components or equipment in the general area.
- c) Make sure that the complete base of the tilter is in contact with the floor. In order to complete contact with the floor, the base may be shimmed or grouted.
- d) The tilters are provided with anchoring holes on the base. Place the tilter in the exact operating position before spotting and drilling holes for the bolts. Bolt the lift securely using floor lag bolts with a minimum of 2000# pull out strength per bolt.



**Install the tilter on a solid and stable surface.**



**All wiring must conform to local code and must be performed by licensed electricians.**

The standard AC single phase motor requires a 120 volt 20 amp fused outlet, do not remove or replace the plug or cord set provided. Do not use an extension cord.



***Do not* tamper with or remove the cover of the electrical junction box. Only authorized, qualified personnel should service the electrical system. Motor direction is critical. This motor has been wired according to its nameplate and should not be tampered with as it may lead to pump or motor failure.**

### **C. HYDRAULICS:**

1. Before using the tilter, check the hydraulic oil level by removing the solid plug from the reservoir. Remove the plug, check for oil and add oil if necessary. See the chart below for correct oil level. Replace the plug with the vented plug provided; if the vented plug is not installed you may damage the pump. *Note:* if a vented plug is not available, the solid plug may be modified by drilling a 1/8 diameter hole through the center of the plug and reinstall.



***Do not* use automotive hydraulic brake or transmission fluids, they will damage seals and pose a serious fire hazard.**

### **D. TESTING THE TILTER WITH NO LOAD:**

Before operating the tilter, read and understand this section.

1. Before testing the tilter, clear the area of any loose material. Be sure the tilter has no obstruction above it or on any side. Using the controls provided, briefly operate the tilter (5-10 seconds). If the tilter begins to rise with a humming sound and functions properly, continue to the full upright position.



**If the tilter does not rise immediately, or there is any operational problem, stop it immediately. Before continuing, check the**

**rotation of the pump and motor and the voltage at motor terminals, again briefly operate the tilter. If the tilter does not move smoothly with the humming sound, stop and review the procedures in the section on troubleshooting (Section 5B).**

2. After raising the tilter completely, lower the tilter completely. It should move slowly and smoothly without a humming sound. If the tilter operates properly, raise and lower the tilter and stop at different levels in order to familiarize yourself with the tilter's operations and movements.

**⚠WARNING**

**As the tilter platform and forks move up and down, pinch points are created at locations near the base of the frame. While operating the tilter the operator should be standing clear of the tilter and container while in use. In that way, the operator's arms, legs or clothing will not be caught in the moving parts. During operations the operator should avoid the pinch point areas which are located on either side of the tilter. See the diagram pointing out the particular pinch points.**

## **SECTION 4** **OPERATION**

### **A. METHOD OF OPERATION:**

All tilters are provided with a special hydraulic relief valve, which is factory preset to the maximum safe capacity of the container tilter (see the nameplate attached to the tilter.) Activating and holding the up switch will energize the motor. The motor is attached to a positive displacement pump which draws hydraulic fluid from the reservoir and transfers it under pressure to the cylinder. This forces the piston forward and the raise to rise in a thirty (30°) to ninety degree (90°) arc. Releasing the up button will stop the tilter. A check valve between the pump and piston holds the platform

in position. Depressing and holding the down button of the switch will energize a solenoid, which allows the oil from the cylinder to return to the reservoir through a preset flow control. This allows the tilter to lower smoothly and at a controlled speed.

**⚠CAUTION**

**Do not maintain the up button on the switch energized if the tilter does not move or has reached its upper limit. This may cause damage to the motor, pump and controls.**

### **B. OPERATION PROCEDURES:**

In order to operate the tilter, follow these operating procedures:

1. Read and understand all the instructions before operating. If the tilter has modifications or accessories, read and understand their functions.
2. Load the tilter correctly. Refer to the attached nameplate for load capacity information.
  - a) Load the tilter while it is in the lowered position.
  - b) *Do not* exceed the maximum rated load (note that load capacity is on the nameplate of the tilter).
  - c) Place the load in the center and at the very back of the platform (pivot end).
  - d) If the load is unstable or may become unstable, fasten it into position.
  - e) Use additional precautions when tilting a load of loose parts. Excessive (what?) can cause parts to fall out of the container.
3. Operate the tilter.
  - a) To raise the tilter, press and hold the up button on the switch.
  - b) To lower the tilter, press the down button on the switch.
  - c) Release the button to stop the tilter in either direction.
4. Wait until the tilter has come to a complete stop before loading or unloading.
5. Stand clear of the tilter when operating in order to avoid injury.

**⚠WARNING**

- **Do not stand, sit or climb onto the tilter.**
- **Do not load or unload a moving tilter.**

- **If the tilter fails to move or exhibits strange movements or sounds, stop immediately. Do not operate the tilter until it has been checked and repaired.**
- **Obey all warning labels.**
- **Load the lift only in the lowered position.**
- **Do not stand near the tilting side when tilting containers of loose parts. Parts may fall out of the container and could harm the operator.**

6. Place the load in the center and at the very back of the platform.
7. If the load is unstable or may become unstable, fasten it into position.
8. Use additional precautions when tilting a load of loose parts of the tilter. Excessive tilting can cause parts to roll out.
3. Operate the tilter.
  - a.) To raise the lift, press and hold the up switch.
  - b.) To lower the lift, press the down switch.
  - c.) Release the switch to stop the lift in either direction.
4. Wait until the lift has come to a complete stop before loading or unloading.
5. All people and unrelated objects must stand clear of the lift when operating in order to avoid personal injury or property damage.

## **SECTION 5**

# **MAINTENANCE**

Generally, the tilter lifts will require little maintenance. However, routine inspection and maintenance will minimize costly repairs or hazardous conditions.

### **⚠ WARNING**

**Before servicing the unit, read and understand this entire section and the section entitled Operating Instructions. Never go under or service a tilter with a load on the platform or with the platform in a raised position. Always service the tilter in a down or chocked position.**

### **A. ROUTINE MAINTENANCE:**

All routine inspection and maintenance should be performed monthly. When servicing the tilter in a partially or fully raised position, chocks or safety pins must be in place to secure the platform during maintenance. Follow the chocking procedure in Section 5B if chocks or safety pins are not available. Contact Presto Lifts for the recommended parts.

1.
  - a) The unit using a power supply of 115 Volt AC must be disconnected from its power source. *Do not* work on electrical parts unless you are a qualified electrician.
  - b) AC 3 phase or high voltage units must have the power disconnected via standard lock out, tag out procedures prior to servicing. *Do not* move the unit in an up or down motion while performing maintenance.
  - c) For performing any maintenance the unit must be fully secured according to Section 5B. *Do not* remove hydraulic lines unless the tilter has been lowered to its fully secured position. This should be verified several times by pushing the down button on the switch.
  - d) When removing hydraulic hoses, crack the fittings slowly to be sure that any hydraulic pressure that may be residual is released.
2. Inspect the following:
  - a) Check the oil level and add oil if necessary according to the instructions on the hydraulic chart and schematic.
  - b) Check the bolts on the pivot bar that holds the tilt platform in place, if loose tighten.
  - c) Check hydraulic lines for damage or leaking. Replace if damaged.
  - d) Check for oil spots or leaks around fitting and tighten.
  - e) Check wiring for damage. Replace immediately if any signs of wear are evident.
  - f) Bearings on all lifts are permanently lubricated and require no servicing. (*Do not* lubricate bearings.)

## B. TROUBLESHOOTING MAINTENANCE:

All servicing should be done by qualified personnel who should have read and understood all of the information provided in the Operating, Installation and Maintenance sections in this manual.

### 1. Tilt will not move.

- a) For the 115 volt and 3 phase AC units:
  - i) Check the power switch, fuses and overload associated with its electrical circuits.
  - ii) Check voltage at motor; motor may have failed.

### 2. Operational noises (tilter is very noisy)

- a) Tilter may be overloaded or jammed. Check load weights and obstructions.
- b) For 115 volt AC motor, check voltage at terminal. May have low voltage.
- c) Oil shortage, reservoir low or oil line failure. Repair or replace.
- d) Down valve open, check wiring. Replace if necessary.

### 3. Motor overheats:

- a) Excessive cycling (15 cycles per hour maximum). Check actual time in use.
- b) Low voltage-check voltage of 120 volt motors.
- c) Oil starvation-check filter on the pump by removing the coil stem from the pump. *Note: do not overtighten the stem when reinstalling.*

### 4. Tilter operating slowly:

- a) Up cycle:
  - i) Oil starvation—check filter in reservoir.
  - ii) Oil viscosity—oil is too heavy or too thin.
  - iii) Air in cylinder—cycle tilter with no load 2 or 3 times and hold down the up button for 10 seconds after bottoming out on each cycle.
- b) Down cycle:
  - i) Down valve dirty—remove and clean. Check oil condition; replace if dirty. *Note: do not overtighten the stem when reinstalling.*

- ii) Pinched hydraulic lines.
- iii) Oil viscosity is too heavy.

### 5. Tilter raises, then fully lowers without power:

- a) Down valve filter is dirty. Remove and clean. *Note: do not over torque when reinstalling down valve.*
- b) Leaking hydraulic lines or fittings (check for telltale oil spots).
- c) Check valve in pump, may not be seating properly. Pump must be replaced.

### 6. Tilter will not lower when energized:

- a) Down solenoid faulty. Check voltage of coil. Check continuity of coil (could be burnt out).

1. Raise the lift to its maximum height.
2. Using only the chock assembly provided, place the square tubing in the wheel tray sideways and adjacent to the welded long lifting eye nut.
3. Insert the pin which is secured to the lift through the holes provided in the wheel tray. Be sure the pin enters both holes and through the center of the tubing.
4. Lower the lift until the wheels come in contact with the chock and hold the “down” button for another 2 seconds.
5. Raise lift, remove and replace chock to its straight position.

## **SECTION 6**

# **SERVICE**

### **A. REPLACING CYLINDER SEALS:**

1. Lower the tilter to its chocked position and hold down switch for an additional 10 to 20 seconds.
2. Disconnect the electrical power:
  - a) 115 volt units must have the plug removed from the receptacle.
  - b) On 3 phase or high voltage units, use proper lock out, tag out techniques (disconnect the power).
3. Disconnect the hydraulic hose from the cylinder and cap the line to prevent hydraulic fluid loss.
4. Remove the cylinder pin.
5. Lift cylinder out of tilter.



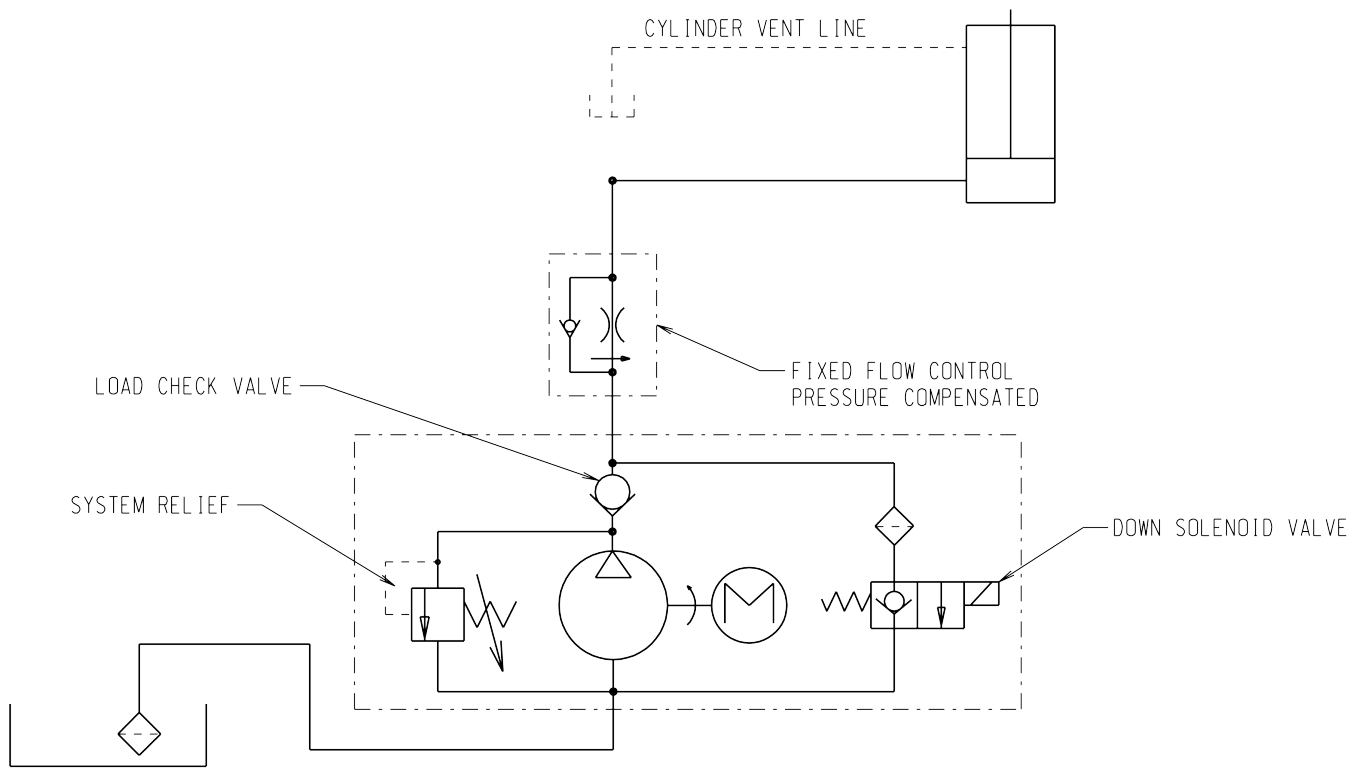
**When disconnecting the hydraulic hose from the cylinder, crack the fittings to be sure that the residual hydraulic fluid pressure that may be in the line is released slowly. Hold the cylinder securely while removing the pin to prevent it from falling to the floor or injuring someone that is servicing it.**

7. Clamp cylinder securely at the base end.
8. Completely collapse cylinder piston.
9. Push gland into the cylinder 1/8".
10. Remove retainer ring.
11. Remove piston rod, piston and gland from cylinder.
12. Remove rod nut, piston and gland.
13. Remove and replace seals and wipers.
14. Assemble piston and gland to piston rod.
15. Assemble rod nut to piston rod and torque to 100 ft/lb.
16. Lubricate piston and seals and install in cylinder.
17. Insert retainer ring.
18. Install cylinder and hydraulic lines.
19. Fill reservoir.

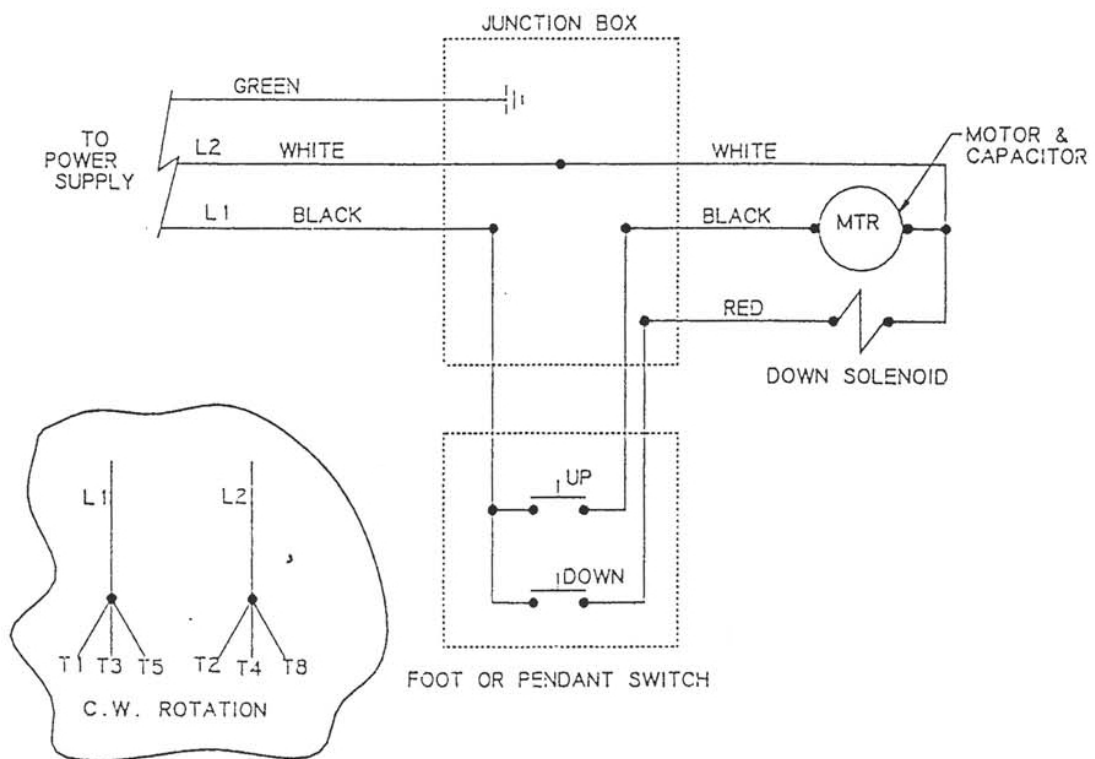
20. For the lifts serviced in the up position, raise table and remove chocks.
21. Cycle tilter 2 to 3 times with no load.
22. Recheck reservoir oil level and fill if necessary.

### **B. ORDERING REPLACEMENT PARTS:**

1. Standard replacement parts for each tilter are provided by part numbers.
2. All key parts are identified and must be replaced with original equipment components.
3. Warranties will be voided where original equipment components are not used.
4. In ordering the replacement parts, be sure to include the serial number and the model number of the tilter you are requesting parts for.

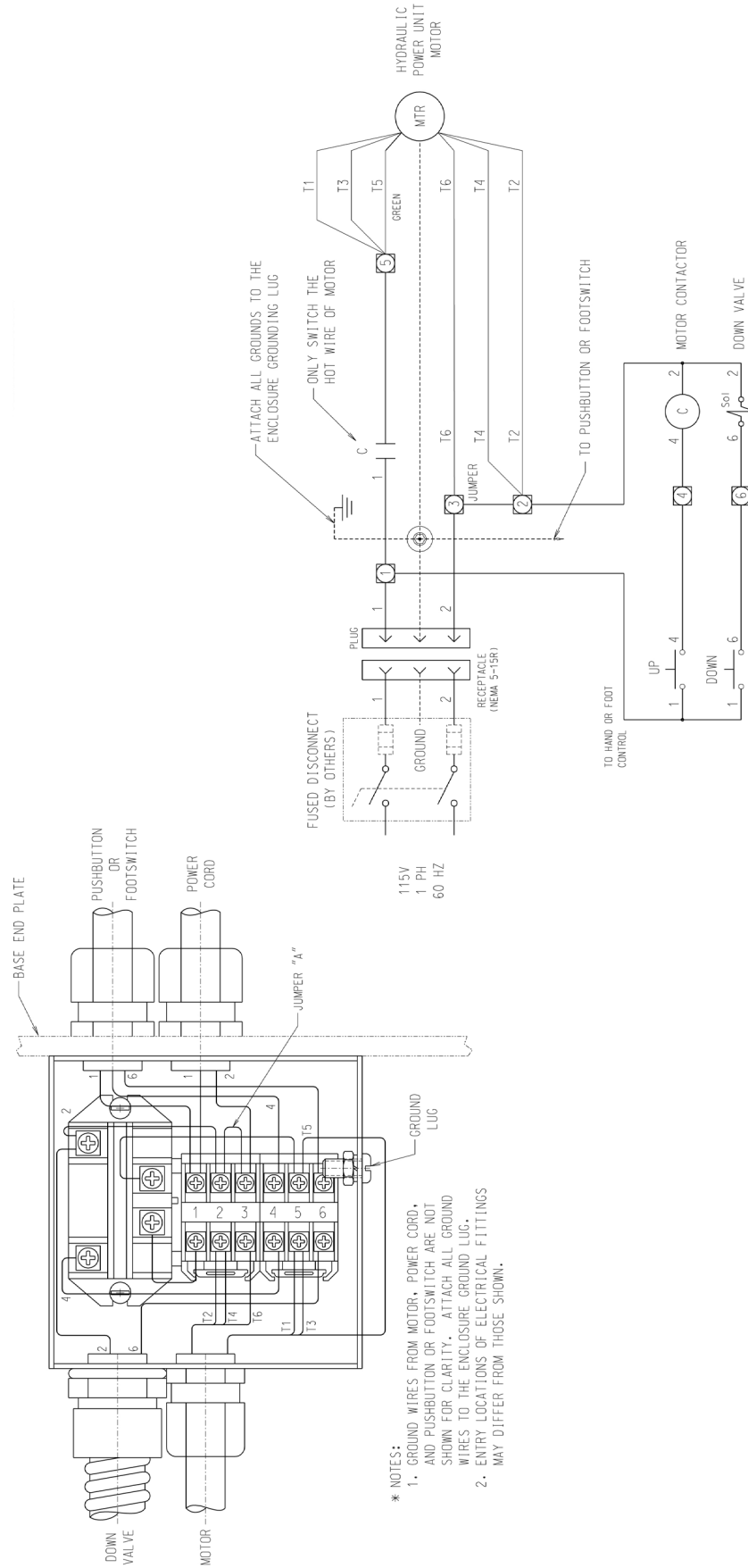


**Figure 1:** Hydraulic Schematic

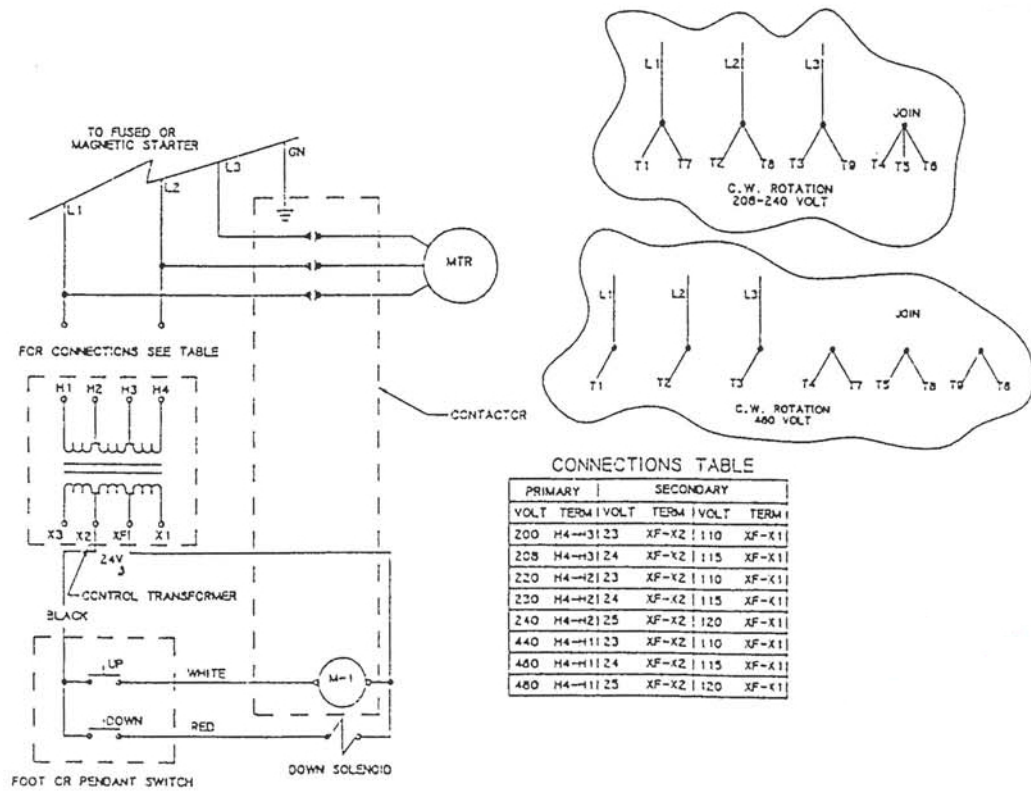


**Figure 2:** Hydraulic Power Unit Wiring Diagram

**Figure 3: Electrical Schematic Pump Unit Single Phase 115 Volts AC**

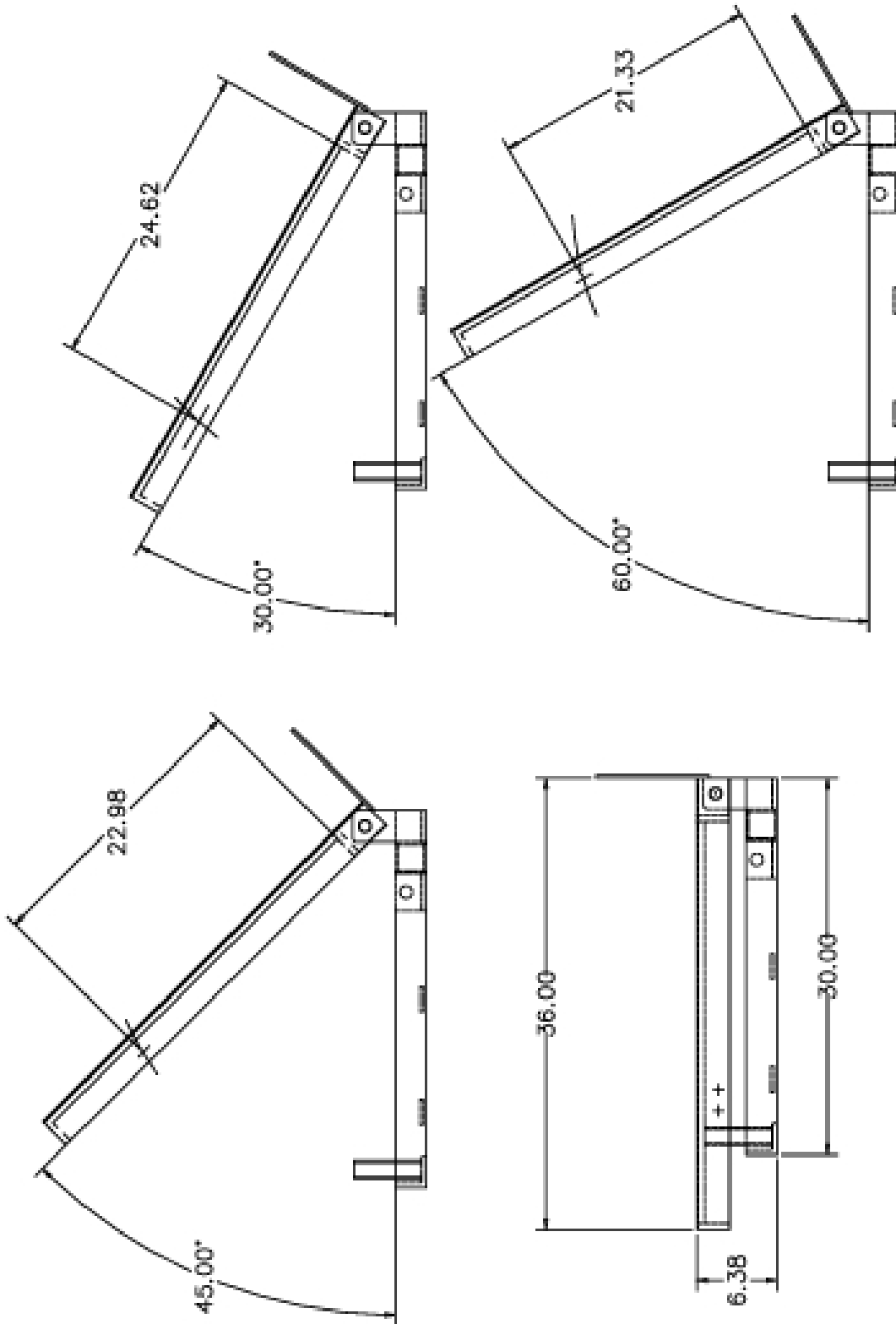




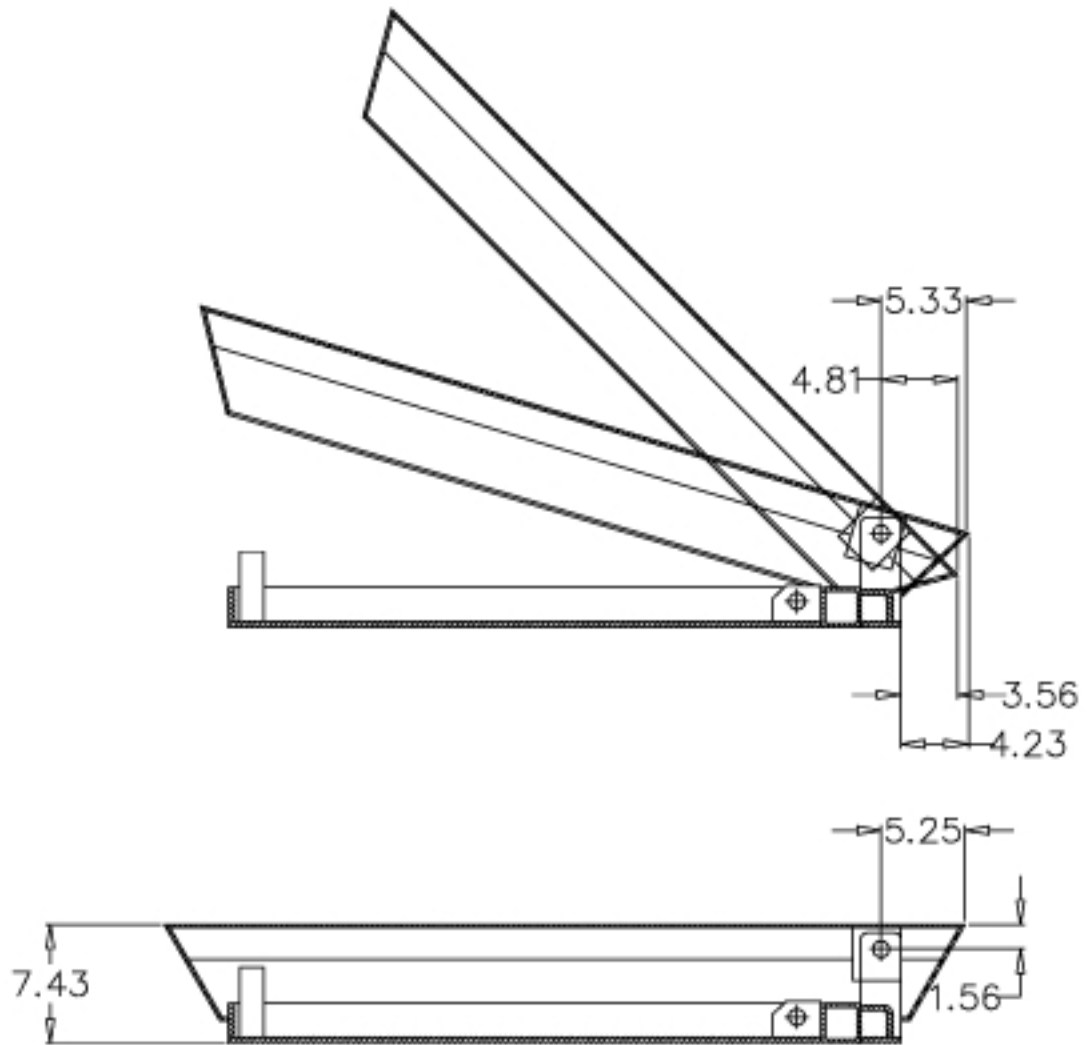


**Figure 4:** Electrical Schematic Pump Unit 1 Phase 208, 240 Volts AC





**Figure 5:** TT Series (Lightweight) Tilt Specifications



**Figure 6:** WT Series (Wide Base) Tilt Specifications

### Table 1 – Hydraulic Oil Specifications

If the lift will be used at normal ambient temperatures, Presto Lifts supplies the unit with Conoco Super Hydraulic 32 oil. This may be replaced by any other good quality oil with 150 SSU at 100° F and rust and oxidation inhibitors and anti-wear properties.

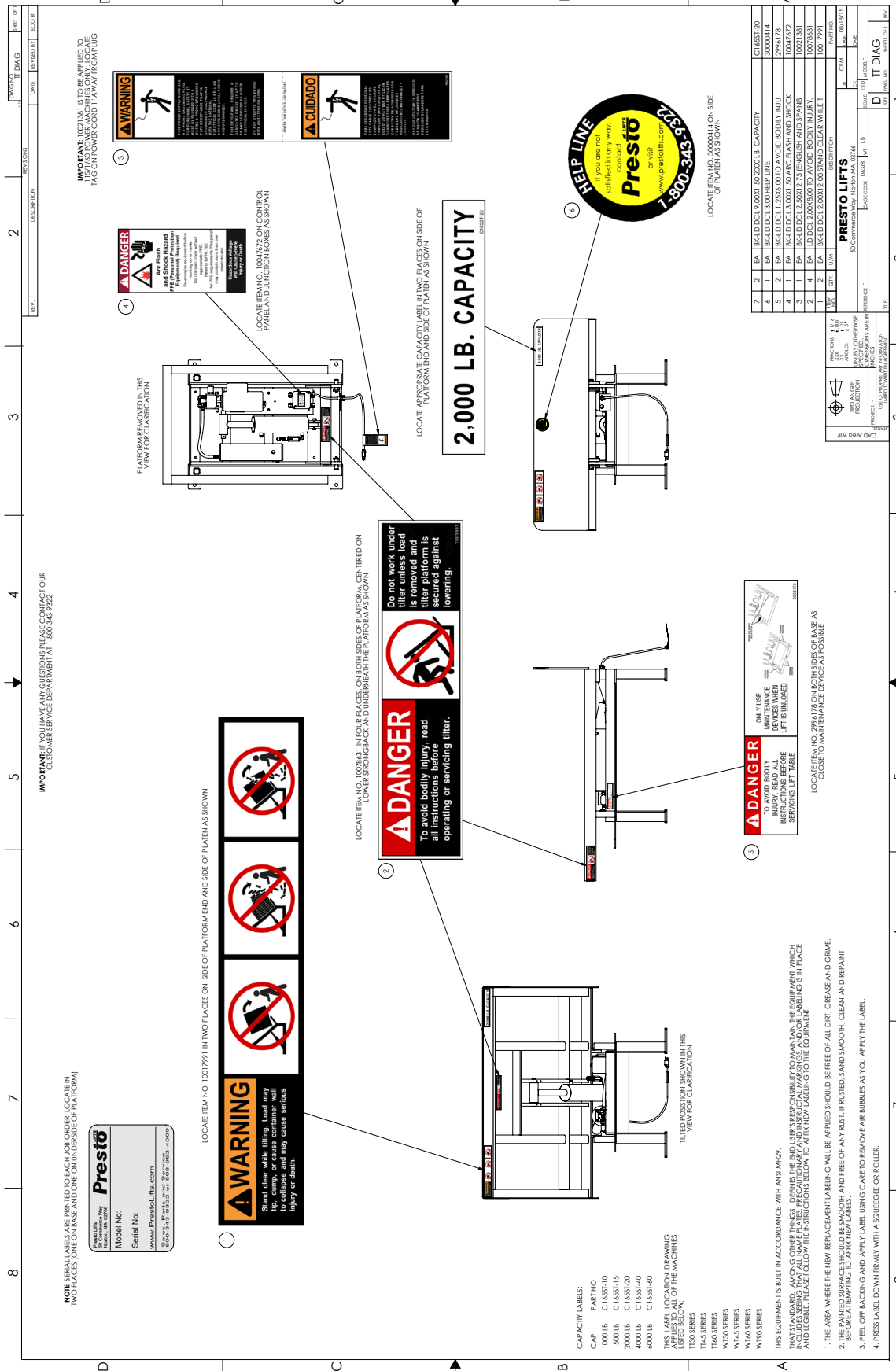
If the lift will be used at ambient temperatures below 0°F, use aircraft hydraulic oil. Use Type 15 aircraft hydraulic oil.

The following are equivalent to Conoco Super Hydraulic 32:

<b>TYPE</b>	<b>MANUFACTURER</b>
AW32 .....	CITGO
DTE 24 .....	EXXON/MOBIL
NUTO H32 .....	EXXON/MOBIL
AMOCO AW32 .....	CHEVRON (AMOCO CO.)

**CAUTION**

It is very important to keep the hydraulic oil free of dirt, dust, metal chips, water, and other contamination. Most of the problems with hydraulic systems are caused by contamination in the oil.



## Ordering Replacement Parts

Presto Lifts has carefully chosen the components in your unit to be the best available for the purpose. Replacement parts should be identical to the original equipment. Presto Lifts will not be responsible for equipment failures resulting from the use of incorrect replacement parts or from unauthorized modifications to the unit.

Presto Lifts can supply all replacement parts for your lift. With your order, please include the model number and the serial number of the unit. You can find these numbers on the name plate. This plate is located within the scissors mechanism.

To order replacement parts, please call the Presto Parts Department. Parts are shipped subject to the following terms:

- FOB factory
- Returns only with the approval of our parts department.
- Credit cards preferred (except parts covered by warranty).
- Freight collect for truck (except parts covered by warranty).
- Freight – prepaid and invoice for small parcel shipments (except parts covered by warranty).
- The warranty for repair parts is 30 days from date of shipment.

Parts replaced under warranty are on a “charge-credit” basis. We will invoice you when we ship the replacement part, then credit you when you return the worn or damaged part, and we verify that it is covered by our warranty. Labor is not covered under warranty for Parts orders.

### **Presto Parts Department**

50 Commerce Way  
Norton, MA 02766

Telephone: 800-343-9322

FAX: 888-788-6496

Email: [service@PrestoLifts.com](mailto:service@PrestoLifts.com)

**[www.PrestoLifts.com](http://www.PrestoLifts.com)**

## **PARTS**

Standard parts may be returned with a 20% restocking fee. Modified or custom-engineered parts are not returnable. Unfortunately, due to potentially concealed damage, all sales of electrical assemblies are final.

## **QUALITY ISSUES**

Should you feel there is a quality problem, please contact the seller to ask questions and gather information on how to rectify the issue. Presto Lift Inc. reserves the right to determine potential credits, as a result of factory defects, based on its inspection of the merchandise.

## **GENERAL**

All products shipped from our factory have passed Quality Assurance inspection and testing. The carrier of choice has signed for, and accepted the product in new working condition. The customer should inspect to ensure it is not received damaged, has no concealed damage or is not incomplete. Parts orders are determined to be complete based upon Presto Lift, Inc. inspection sheets and carrier shipping weights.

## **RETURN MATERIALS AUTHORIZATION POLICY**

Presto Lifts provides the Return Materials Authorization (RMA) Policy, for specific models, as a courtesy to our distributors in the event they do not receive what they ordered. If a customer wishes to return a Presto Lifts product, please contact the Customer Service Department and request an RMA number. This request must be made on or before the fifteenth calendar day following the date of Presto Lifts' invoice for the merchandise. Not all units are returnable. Quantity orders and special designs cannot be returned under any circumstances. Presto Customer Service reserves the right for final judgment on all product returns.

The RMA number must appear on the outside of any packaging material for a return to be accepted and processed by Presto Lifts. Customers shipping returns from the Continental US, Canada, or Mexico have thirty (30) days from date of RMA issue to have the product arrive at Presto Lifts' facility. All merchandise must arrive Free on Board at Presto Lifts' facility or the shipment will be refused and returned to the sender. All credits are issued less restocking and refurbishing charges, regardless if the merchandise was damaged in transit.

Return addresses: please refer to your RMA for the address to which your product should be returned.

Presto Lift Inc.  
715 Highway 77  
Manila, Arkansas 72442

Telephone: 800-343-9322  
Fax: 888-788-6496