

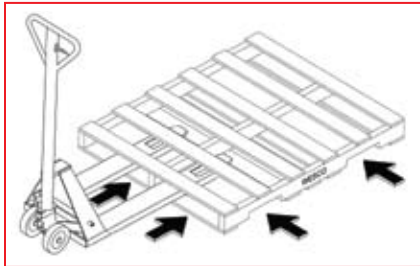

273400



4-Way Pallet Truck

- 3 year pump warranty.
- Overload bypass.
- Reinforced forks.
- Rubber coated handle.
- 101° steering
- Can enter pallet from all 4 sides.
- Adjustable fork connecting rods.
- Steel 1.70" load wheels.
- 6" polyurethane steering wheels.

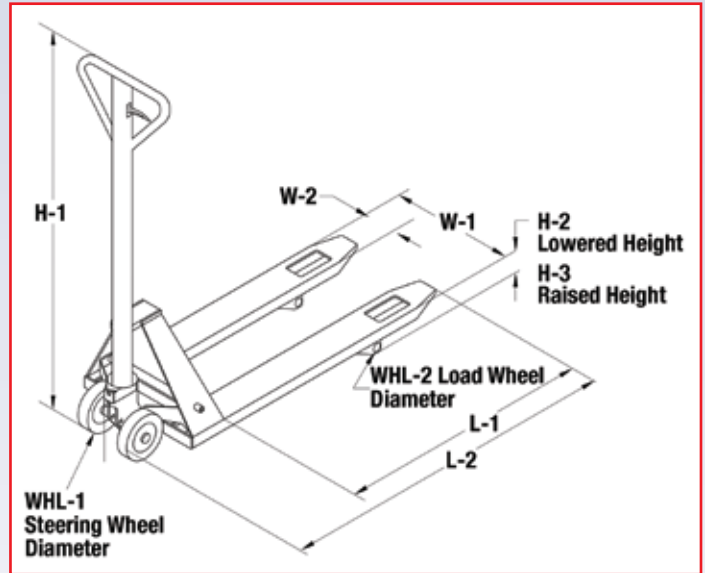

272667

LOOK - BRAKE

Pallet Truck With Hand Brake

- 2 year pump warranty.
- All the same features as the CPI model.
- 6" wide forks.
- 7" moldon polyurethane steeringwheels.
- 3" moldon polyurethane load wheels.
- Disc brake.
- Tandem load wheels.



272149

MOST ECONOMICALLY PRICED PALLET TRUCK

Economizer Pallet Truck

- 1 year pump warranty.
- Fingertip control: raise - neutral - lower.
- Polyurethane load and steering wheels.

| Part # | 273400 |
|---------------|------------------|
| Capacity | 4,000 lbs |
| W-1 x L-1 | 33" x 48" |
| W-2 | 6.75" |
| L-2 | 59" |
| WHL-1 / WHL-2 | 6" / 1.7" |
| H-1/H-2/H-3 | 47" / 1.75" / 6" |
| Weight | 241 lbs |

| Part # | 272667 |
|---------------|-----------------------|
| Capacity | 5,500 lbs |
| W-1 x L-1 | 27" x 48" |
| W-2 | 6" |
| L-2 | 63" |
| WHL-1 / WHL-2 | 7" / 3" |
| H-1/H-2/H-3 | 48.25" / 2.9" / 7.25" |
| Weight | 206 lbs |

| Part # | 272149 |
|---------------|----------------------|
| Capacity | 4,400 lbs |
| W-1 x L-1 | 27" x 48" |
| W-2 | 6" |
| L-2 | 63" |
| WHL-1 / WHL-2 | 6.25" / 3" |
| H-1/H-2/H-3 | 48.25" / 2.9" / 7.5" |
| Weight | 136 lbs |

Distributed By:
Custom Equipment Company
 Tom McGovern
 866-333-0728
 Sales: tom@custommhs.com
 www.custommhs.com