

LINEAR ACTUATED MOBILE TILTING WORK TABLE - WT-2424-LA

APPROX WEIGHT: 97.68 lbs.
 DOES NOT INCLUDE WEIGHT OF POWER OR PACKAGING!!!

*** ANY ADDITIONS, DELETIONS, OR OMISSIONS MUST BE CORRECTED ON THIS DRAWING AS THIS DRAWING WILL BE CONSIDERED ALL INCLUSIVE ***
 ALL GRAPHICS PROVIDED ARE FOR REFERENCE ONLY. IF CERTAIN DIMENSIONS ARE CRITICAL PLEASE VERIFY THOSE DIMENSIONS WITH YOUR SALESPERSON

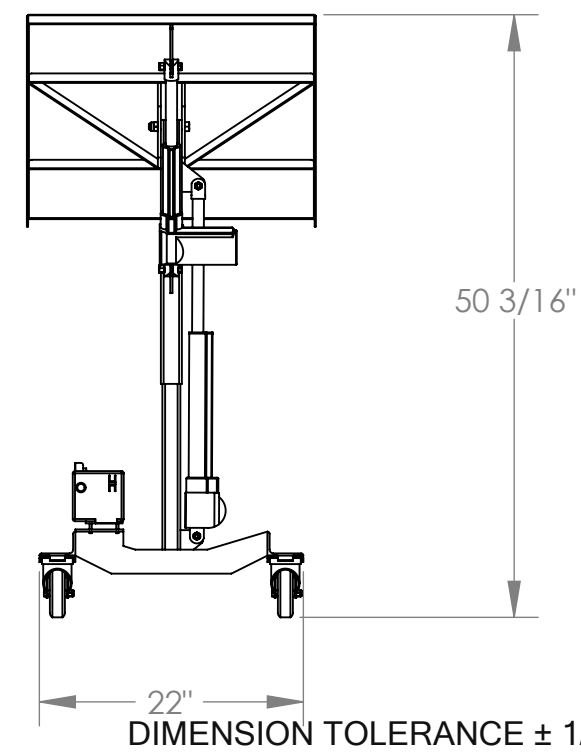
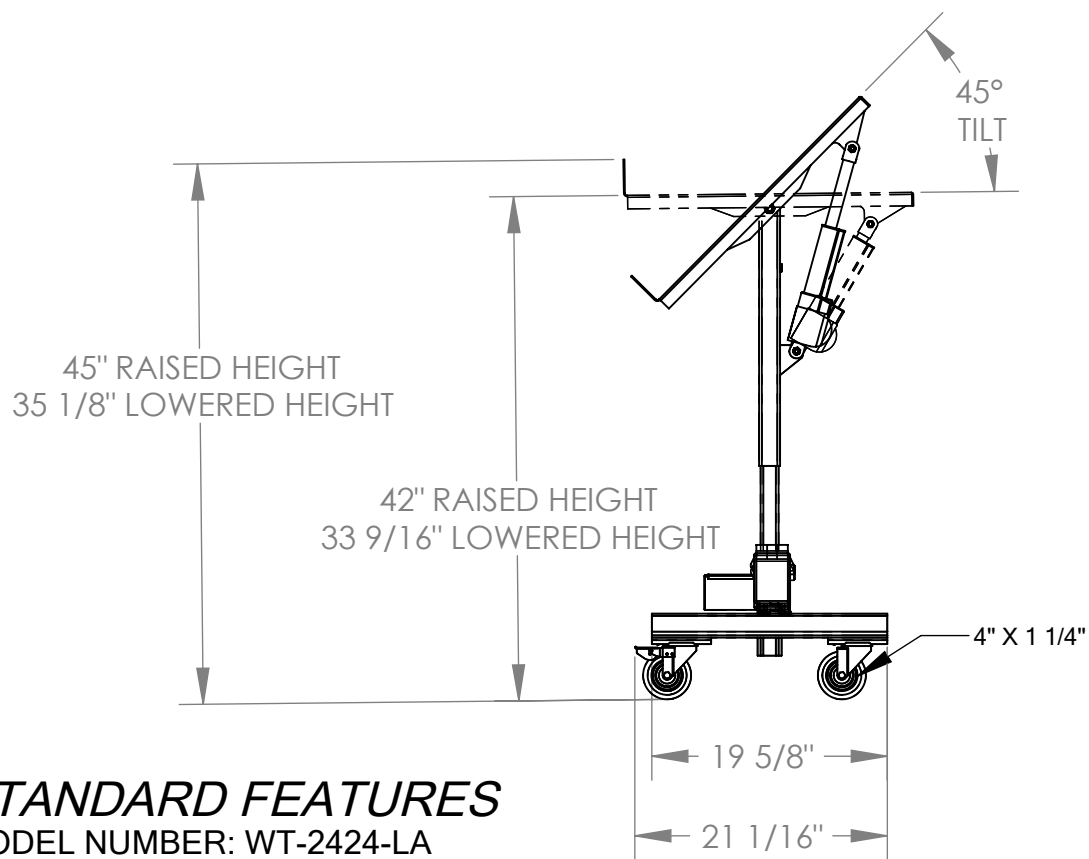

STANDARD FEATURES

- MODEL NUMBER: WT-2424-LA
- BASE WIDTH: 22"
- BASE LENGTH: 21 1/16"
- RAISED HEIGHT: 42"
- LOWERED HEIGHT: 33 9/16"
- CAPACITY: 300 LBS
- PLATFORM WIDTH: 24"
- PLATFORM LENGTH: 24"
- DEGREE OF TILT: 45°
- TWO SWIVEL 4" X 1 1/4" POLYURETHANE DOUBLE-LOCKING CASTERS (FRONT)
- TWO SWIVEL 4" X 1 1/4" POYURETHANE CASTERS (REAR)

SPECIAL FEATURES

NONE

NOTE: DEWERT FOUR BUTTON HAND CONTROL NOT SHOWN

PLEASE CIRCLE SPECIFICATIONS:

POWER	AC	*DC (12V)	* AIR/OIL
MOTOR VOLTAGE	115	208	230 460
DEDICATED CIRCUIT REQUIRED			
MOTOR PHASE	SINGLE	THREE	
CONTROL	HAND	* FOOT	
~ ALL BATTERY CHARGERS ARE 115V AC ~			
* BATTERY CHRG.	REMOTE	ON-BOARD	
* CHRG. INDICATOR	YES	NO	

* AVAILABLE AT ADDITIONAL COST

I, THE UNDERSIGNED, AGREE THAT THE PRODUCT AS REPRESENTED SATISFIES DESIGN AND DIMENSION REQUIREMENTS. I ALSO ACKNOWLEDGE MY DUTY TO CONFIRM PRODUCT AND INSTALLATION COMPLIANCE WITH ALL APPLICABLE FEDERAL, STATE AND LOCAL REGULATIONS AND STANDARDS.

ALL SPECIAL UNITS ARE NON-RETURNABLE

[] As drawn [] As marked

Signed: _____ Date: _____

LEAD TIME WILL START UPON RECEIPT OF SIGNED APPROVAL DRAWING

DISTRIBUTOR'S NAME:		P.O.#
VESTIL MANUFACTURING		X
DRAWN BY: SR		W.O.#
DATE: XX/XX/XX		X
REFERENCE: X	SCALE: 1:16	SALES: X
QUOTED LEAD TIME: X	QUOTE # X	FILE NAME:
		16-007-022