

- LOW PROFILE HOPPER - MODEL: SLPT-24

APPROXIMATE WEIGHT IS: 99.2 lbs.

*** ANY ADDITIONS, DELETIONS, OR OMISSIONS MUST BE CORRECTED ON THIS DRAWING AS THIS DRAWING WILL BE CONSIDERED ALL INCLUSIVE ***

ALL GRAPHICS PROVIDED ARE FOR REFERENCE ONLY. IF CERTAIN DIMENSIONS ARE CRITICAL PLEASE VERIFY THOSE DIMENSIONS WITH YOUR SALESPERSON

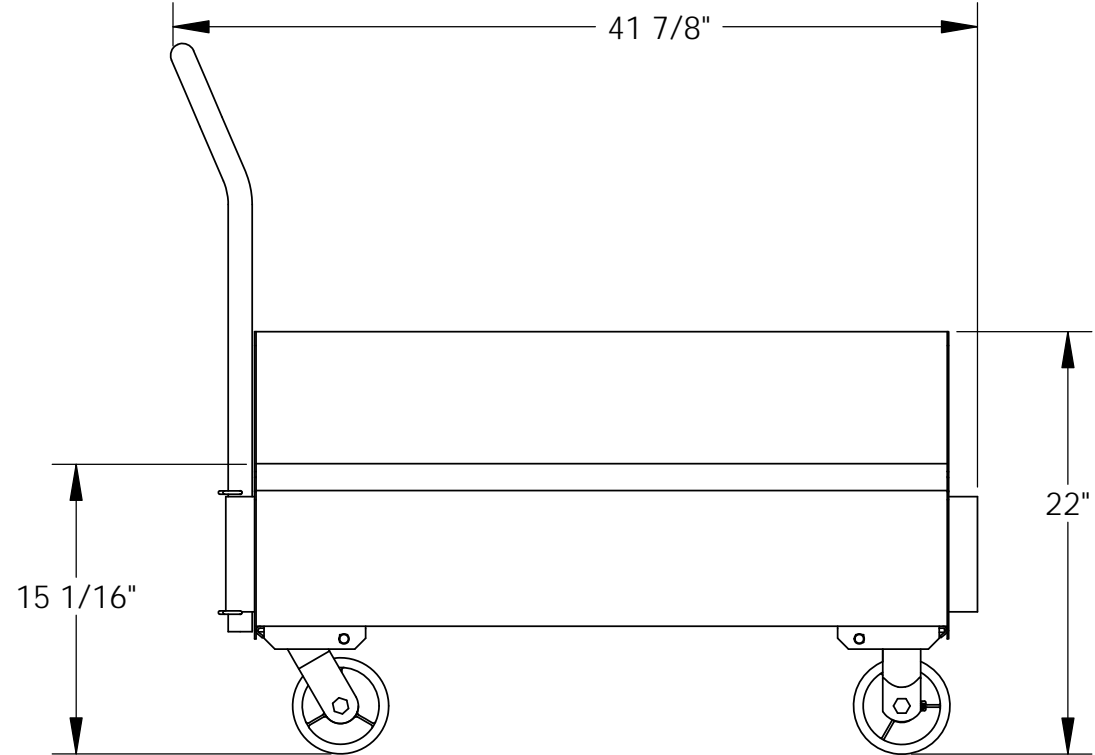
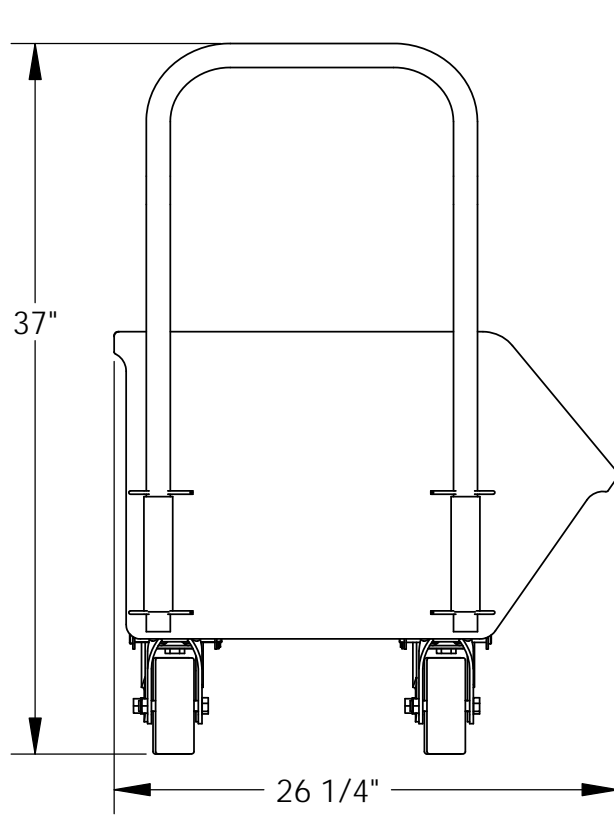

STANDARD FEATURES

- OVERALL WIDTH IS: 26 1/4"
- OVERALL LENGTH: 41 7/8"
- OVERALL HEIGHT: 37"
- HOPPER BOX WIDTH: 24 1/2"
- HOPPER BOX LENGTH: 36"
- HOPPER BOX DEPTH: 15 1/4"
- HOPPER VOLUME: 6.9 cu-ft; 1/4 cu-yd
- HOPPER CAPACITY: 1000 lbs.
- REVERSABLE/ REMOVABLE HANDLE

SPECIAL FEATURES

NONE

ALL SPECIAL UNITS ARE NON-RETURNABLE

APPROVAL	I, THE UNDERSIGNED, AGREE THAT THE PRODUCT AS REPRESENTED SATISFIES DESIGN AND DIMENSION REQUIREMENTS. I ALSO ACKNOWLEDGE MY DUTY TO CONFIRM PRODUCT AND INSTALLATION COMPLIANCE WITH ALL APPLICABLE FEDERAL, STATE AND LOCAL REGULATIONS AND STANDARDS.	
	ALL SPECIAL UNITS ARE NON-RETURNABLE	
	[] As drawn [] As marked	
	Signed: _____	Date: _____
LEAD TIME WILL START UPON RECEIPT OF SIGNED APPROVAL DRAWING		

DISTRIBUTOR'S NAME:		P.O.#
		W.O.#
DRAWN BY:	W. STALEY	DATE: 3/7/08
REFERENCE:		SALES:
QUOTED LEAD TIME:	SCALE: 1:10	FILE NAME:
	QUOTE #	37-007-069