

# WESCO® ERGONOMIC DRUM HANDLERS

Now five models, all with U.S. Patented Gator Grip *U.S. Patent No. 6,619,905.*



STEEL



FIBER



POLY

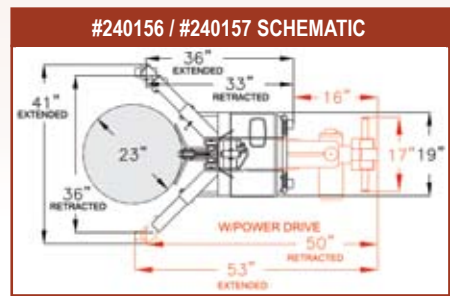
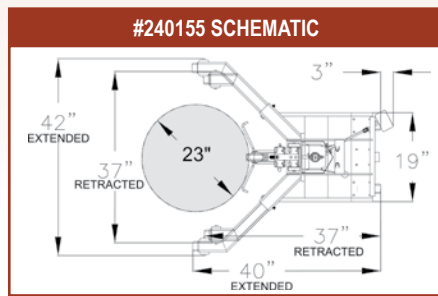
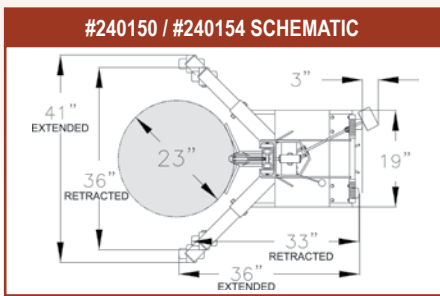
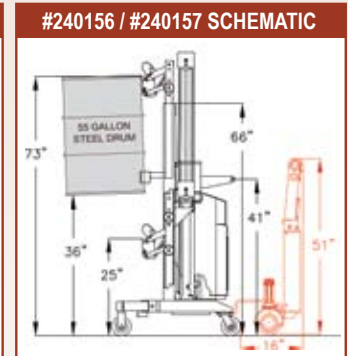
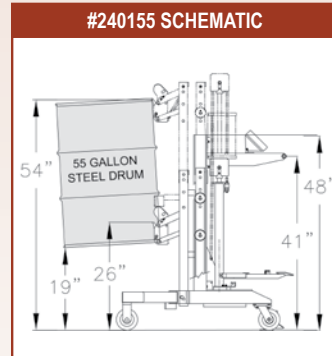
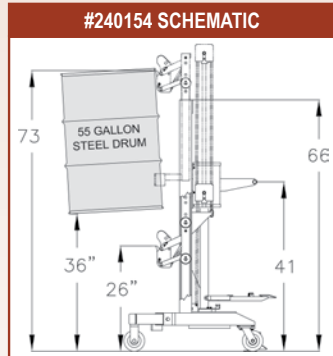
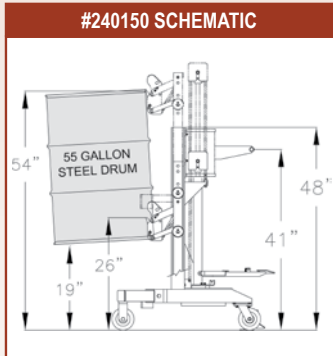

## Wesco® Ergonomic Drum Handlers

- 5 models: **Standard, High Reach, Scale, Power Lift, Power Lift & Drive**
- Ergonomic solution for lifting, transporting, weighing and placing drums on spill or standard pallets.
- Spring-loaded clamp holds any 3/16" or higher drum rim.
- (2) wheels and (2) swivel casters, 5" x 2" phenolic, and floor lock.
- Handles most 30, 55 or 85 gallon drums - Steel, Fiber and Poly.
- Works with most drums with locking rings.
- Operator does not need to touch drums to operate.
- Exclusive auto grip lock will not drop a drum.
- Up/Down remote on power units.
- Power drive travel speed 120'/min.



Standard Model



High Reach Model



Scale Model - Accuracy ± .5 lbs.



Power Lift



Power Lift & Drive

Part #	240150	240154 <b>NEW!</b>	240155 <b>NEW!</b>	240156 <b>NEW!</b>	240157 <b>NEW!</b>
Model #	DM-1100	DM-1100-HR	DM-1100-S	DM-1100-PL	DM-1100-PLD
Description	Standard	High Reach	Scale	Power Lift	Power Lift & Drive
Rise/Stroke	1"	1"	1"	8.5" / sec. without load	8.5" / sec. without load
Legs Retracted Capacity	650 lbs	650 lbs	650 lbs	650 lbs	650 lbs
Legs Extended Capacity	1100 lbs	1100 lbs	1100 lbs	1100 lbs	1100 lbs
Weight	355.5 lbs	376lbs	356 lbs	531 lbs	691 lbs

Distributed By: Custom Equipment Company  
 Tom McGovern, 866-333-0728  
 Sales: tom@custommhs.com  
 www.custommhs.com

DRUM HANDLING EQUIPMENT