



## Specification Sheet

### Short Form Specifications

Eagle Black Polymer Utility Cart, model EU3-2030-P. Shelves and handles are heavy duty black polymer—three shelves, one push handle per end. Uprights are brushed aluminum. 4"-dia. non-marking swivel casters. Weight capacity up to 200 lbs.



*black polymer utility cart*

Item No.:	_____
Project No.:	_____
S.I.S. No.:	_____

## Black Polymer Utility Cart

### MODELS:

**EU3-2030-P**

- Heavy duty black polymer shelves with lip on three sides.
- Heavy duty black polymer push handle on each end of cart.
- High style appearance with brushed aluminum uprights.
- 4" (102mm)-diameter non-marking swivel casters.
- 37¼" (959mm) overall height, including casters.
- 200 lb. (90.7 kg) weight capacity per cart.

**For More Information: 866-333-0728**  
**Custom Equipment Company**  
**Sales: [sales@customMhs.com](mailto:sales@customMhs.com)**  
**[www.customMhs.com](http://www.customMhs.com)**



Item No.: \_\_\_\_\_  
 Project No.: \_\_\_\_\_  
 S.I.S. No.: \_\_\_\_\_

# Black Polymer Utility Cart

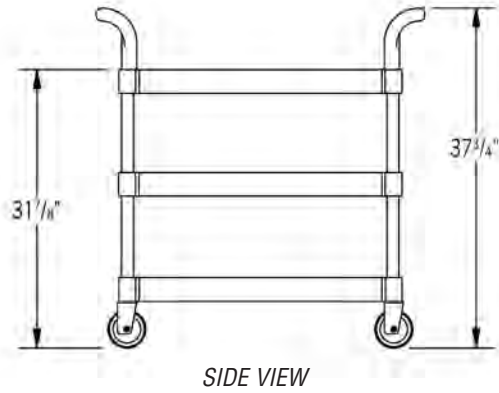
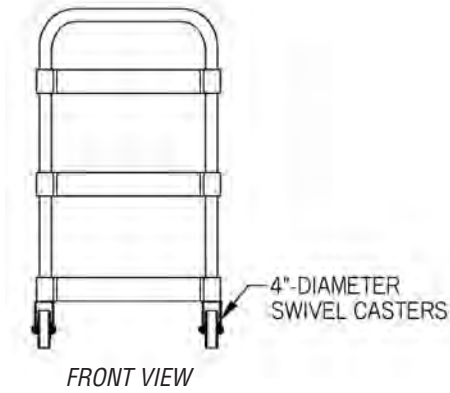
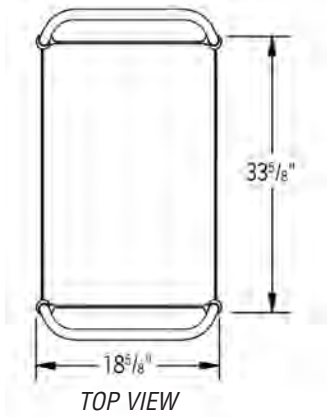

model #	width x length		weight capacity		weight	
	in.	mm	lbs.	kg	lbs.	kg
EU3-2030-P	18 5/8"	473	200	90.7	30	13.6

**For More Information: 866-333-0728**  
**Custom Equipment Company**  
**Sales: sales@customMhs.com**  
**www.customMhs.com**