

## Drum Strap, Lift, Rotate

ROTO LIFT, POWER DRIVE



Roto-Lift drum handlers lift, rotate, and dump most steel, fiber, and plastic drums and cylinders (14" -24" in diameter) with ratchet straps. Transporting, lifting, and tilting drums and containers is safer and easier than ever before with the power drive Roto-Lift. 12" power drive wheels plus full-function hydraulic lift and pour means any operator can effortlessly move drums up to 1,000-lbs. A powered drum handler can provide substantial cost savings by eliminating the need for fork lifts. These units feature fully adjustable and programmable controls with 1-2.5 mph speed controls (2.5 mph factory set max) and can easily handle grades up to 5-degrees. Features a 24-volt DC system, battery indicator gauge, and a keyed On/Off switch. Includes two batteries and 12V AC charger.

Part Number	F89832A5	F89831A4	F89838A2	F89837A1
Name	78" Counter	90" Counter	78" Straddle	90" Straddle
Load Capacity	1,000 lbs	1,000 lbs	1,000 lbs	1,000 lbs
Weight	1,400 lbs	1,450 lbs	750 lbs	800 lbs
Width	32"	32"	30"	32"
Length	51"	51"	47"	47"
Height	78"	90"	78"	90"
Drum Diameter	14 - 24"	14 - 24"	14 - 24"	14 - 24"
Drive Speed	1 - 2.5 MPH	1 - 2.5 MPH	1 - 2.5 MPH	1 - 2.5 MPH
Lift Speed	3.4" / second	3.4" / second	3.4" / second	3.4" / second
Rotate Speed	6 RPM	6 RPM	6 RPM	6 RPM
Max lift travel	58"	71"	58"	71"
Turning Radius	71"	71"	48"	48"



F89832A5  
78" Counter Roto Lift

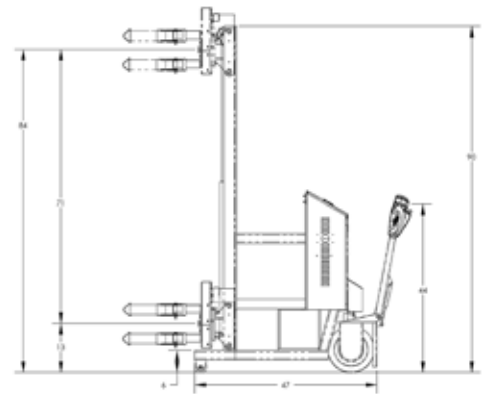
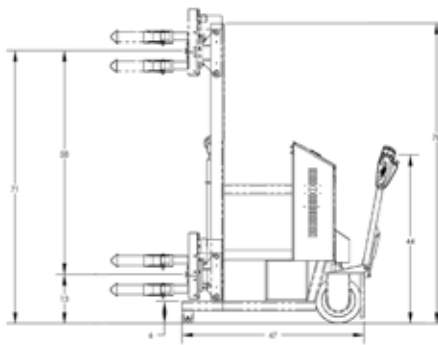
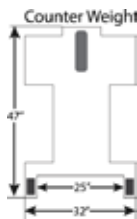

F89838A2  
78" Straddle Roto Lift

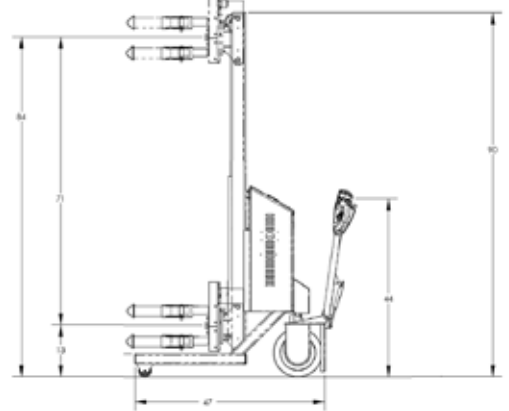
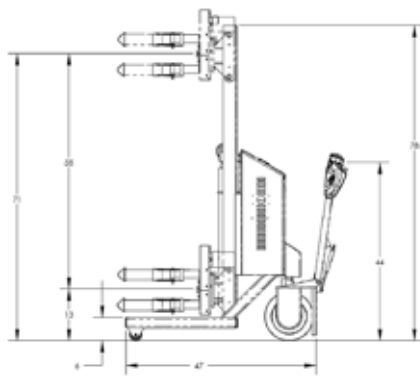
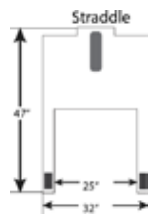

Curtis TM-1 Tiller head equipped with emergency reverse switch, electronic throttle, rocker switches, horn, and gas spring to automatically return head to upright position when not in use.