

BOXED BEEF TRUCK

APPLICATION:

Ideal for use in walk-in coolers and freezers, these trucks are perfect for transporting/storing large loads of beef, stock, produce, etc..

MATERIAL:

BASE: Perimeter frame of 1 1/2" x 2 3/4" x .070 wall extruded aluminum tube with 1 1/2" x 1 1/2" x .070" wall tube laterals.

UPRIGHTS: 1 1/2" x 1 3/4" x .070 wall extruded aluminum tube with horizontal braces of 1 1/2" x 1 3/4" x .070 wall extruded tubing and welded securely to the base.

UPPER SHELF: Frame consists of 1 1/2" x 3 1/8" x .070" wall aluminum tube and of 1 1/2" x 1 1/2" x .070" wall aluminum tube laterals.

CASTERS:

These trucks come equipped with four 6"x2" platform type casters (two swivel and two rigid).

GUARANTEE:

These trucks carry a **Lifetime Guarantee** against rust and corrosion and also a **Five-Year Guarantee** against material defects and workmanship.



Model #1151



New Age Industrial reserves the right to modify or make changes at any time without notice to materials and specifications.

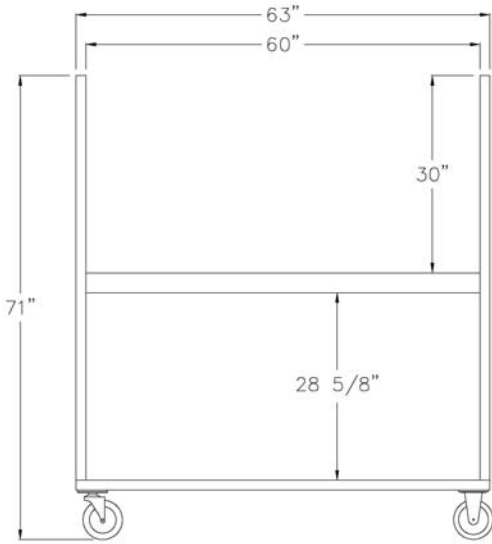

Model #1151

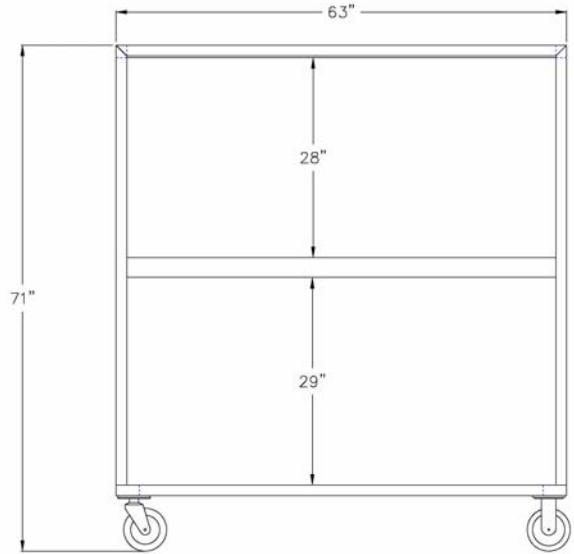

Model #1152

Model No.	Size-W	Size-H	Size-D	No. Of Shelves
1151	27"	71"	63"	2
1152	27"	71"	63"	3



Distributed by: Custom Equipment Company
 866-333-0728
 sales@custommhs.com
 www.custommhs.com



New Age Industrial reserves the right to modify or make changes at any time without notice to materials and specifications.