

## 97769 - Correctional Duty Utility Cart

Ideal three-shelf unit for various tasks such as serving, bussing and general utility.

Strength and durability of stainless steel at much less the cost.

- Hi-tensile, corrosion resistant, rust proof, primary extruded aluminum, Type 6463-T5 alloy.
- All heli-arc welded with seams welded (no rivets).
- Heavy duty all welded frame construction consists of 1" x 1" x .070 wall extruded aluminum tube.
- Each shelf is constructed of a .080 aluminum sheet with three 1 1/4" lips (full 1 1/4" hem) up and one full 1 1/4" hemmed lip down.
- Constructed of 1/4" x 1 1/2" aluminum strap welded to the frame uprights with round tube handle bolted in place.
- Four 5" diameter platform type casters with non-marking wheels; two swivel, two rigid.

**Lifetime Guarantee** against rust and corrosion.

**Five-Year Guarantee** against material defects and workmanship.

**NSF Certified.**



Model No.	Size W-H-D	Shelf Size	Shelf Spacing	Wt. Cap.	Ship Lbs.
97769	18 1/2" x 39" x 32 1/2"	18 1/2" x 28 3/4"	14 1/2"	550#	45

Four 5" plate type casters: two swivel (#C450) two rigid (#C460) with tamper proof fasteners.

**Three tier solid shelf unit:** each shelf with three sides up 1 1/4" and one side down 1 1/4".

**Options:**

"B", "CL(B)", "VB" — see page 69 for details.

**Corner Bumpers** - Add "B" suffix to model #.

**Caster Locks (2)** - Add "CL" suffix to model #.

**Vertical Bumpers (4)** - Add "VB" suffix to model #.

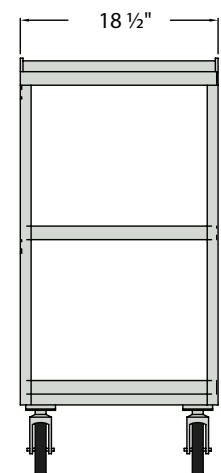
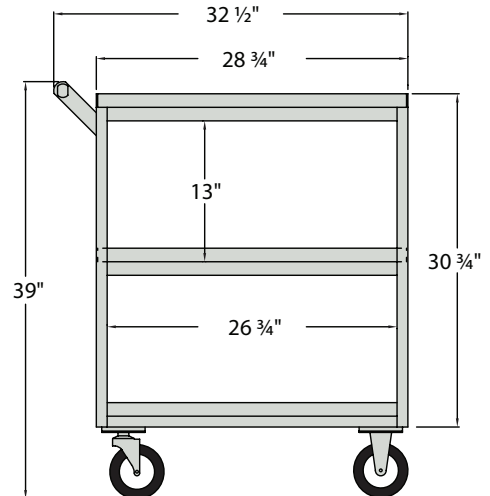

This information is for general sales and engineering use only. New Age Industrial reserves the right to modify or make changes at any time without notice to materials and specifications.

