

261036

POWERED STACKER 1,000 LBS

Features:

- Remote control, floor lock, and safety screen are standard on all models.
- With a minimally charged battery, unit can be used while recharging.
- Three light LED charge status indicator - No extra cost.
- Easy to read illuminated battery status voltmeter - No extra cost.
- 12V DC battery or 110V AC units available.

ADJUSTABLE SPAN STRADDLE MODEL

- Extra deep (40") straddle legs and forks for lifting pallets.
- Versatile adjustable span straddle legs can be set from 34" to 50" inside dimension to handle most standard pallets.

Model: **PASFL-76-40S**
 Lift Height: 76"
 O.A.H: 92"
 Weight: 554 lbs
 Leg ID/OD: 34" TO 50"
 Capacity: 1,000 lbs
 Load Center: 20"

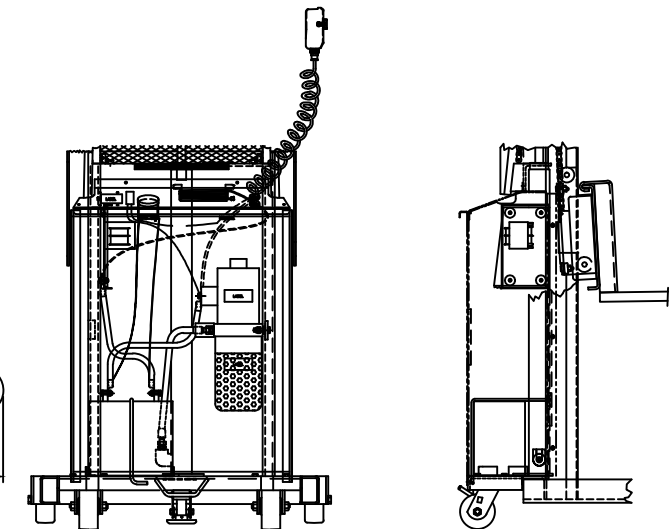
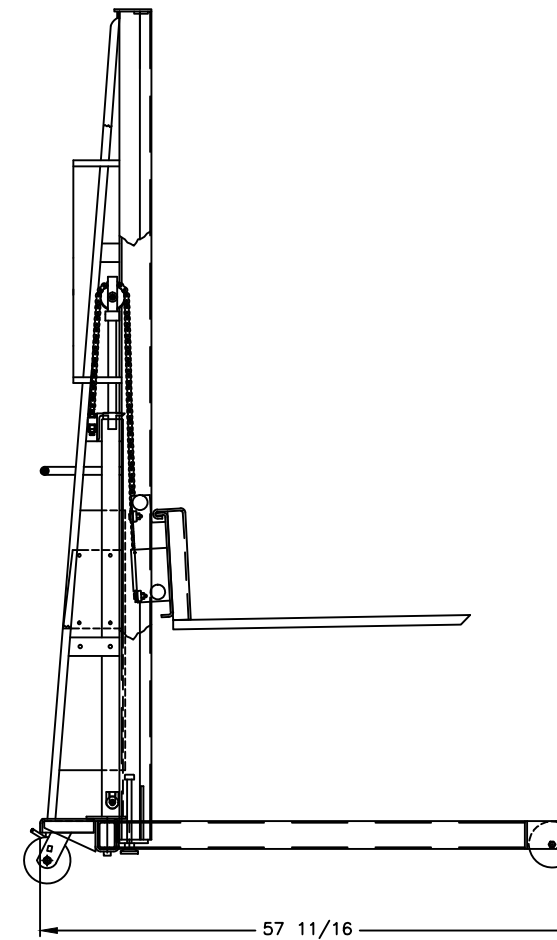
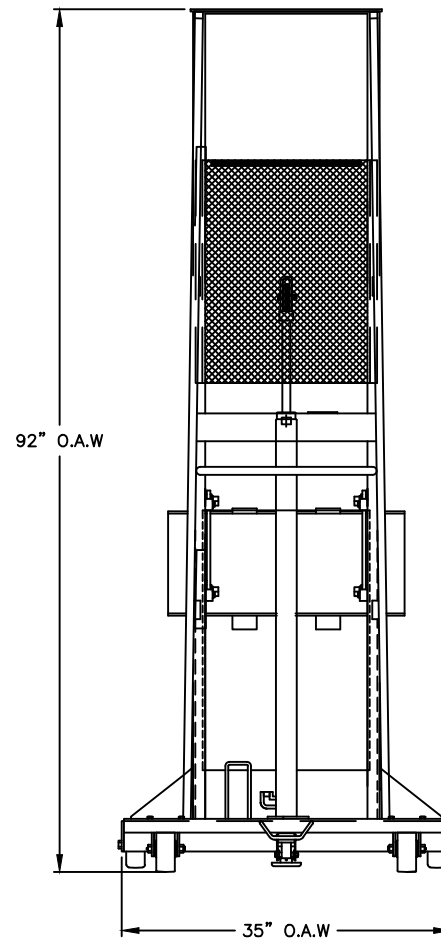

POWER UNIT

**POWER-LIFT STACKER PARTS LIST
76"/80" LIFT**

1	051163	HYDRAULIC CYLINDER	1
2	109101	POWER UNIT	1
3	109102	BATTERY	1
4	109104	VOLTMETER	1
5	052769	BATTERY CABLE (NEG.)	1
6	052770	BATTERY CABLE (POS.)	1
7	109114	BOARD: INDICATOR LIGHT	1
8	052762	BATTERY CHARGER	1
9	125824	HYDRAULIC HOSE	1
10	052726	REMOTE CONTROL ASS'Y	1
11	109325	SWITCH	1
12	050772	LIFT CHAIN ASS'Y	1
13	260143	ROLLER CARRIER ASS'Y	1
14	150001	FLOOR LOCK	1
15	053769	WHEEL	2
16	054265	CASTER	2
17	109117	SOLENOID	1

HYDRAULIC CYLINDER PARTS LIST

18	051192	CYLINDER	1
19	051195	PISTON	1
20	051198	CYLINDER CAP	1
21	220170	SEAL KIT	1

THIS DRAWING IN ALL PARTICULARS IS WESCO INDUSTRIAL PRODUCTS INC. PROPERTY. ALL RIGHTS OF DESIGN, INVENTION OR USE OF ARE RESERVED.

PRINT ISSUED
 OTC. 16, 2006
 WESCO MANUFACTURING
 ENGINEERING DEPARTMENT

APP	WESCO INDUSTRIAL PRODUCTS INC.		LANSDALE PENNA. 19446	
	PART NAME		DRAWN: KL 08-07-01	
ECN & DATE	PASFL-76-40S		CHECKED: PS 08-16-01	
	TOLERANCE UNLESS OTHERWISE SPECIFIED		APP. ENGR.	
REVISIONS	FRACTION	3 PLACE DECIMAL	SCALE: 1" = 20"	
	± 1/64	± .005	SHEET 1 OF 2	
	ANGULAR ± 1-1/2'	BREAK ALL SHARP EDGES AND REMOVE ALL BURRS		
REV.	B-261036		REV	