

**POWERED STACKERS**

**Features:**

- Adjustable base legs available on fork models.
- Fixed platforms 24x24, 24x27, 30x32
- Reinforced frame and base.
- Double chain, lift support.
- Heavy-duty pump.
- Ergonomic "D" handles.
- 110V AC models available.

**ADJUSTABLE FORK MODELS**

Model: PSFL-86-25-20S-1.5K  
 Lift Height: 86"  
 O.A.H: 104"  
 Weight: 596  
 Capacity: 1,500 lbs  
 Load Center: 15"  
 Fork W/L: 3"/25"  
 Base Leg ID/OD: 20"/26"

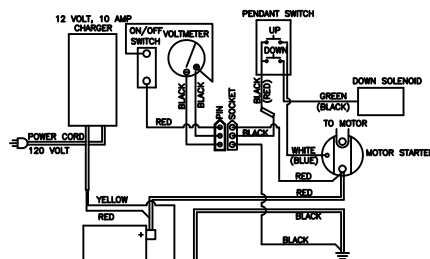

**WIRING DIAGRAM**

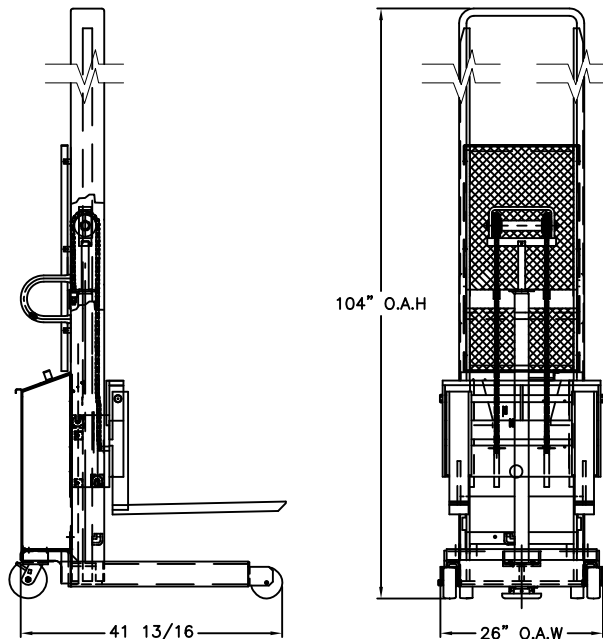

**1,500 LBS POWER STACKER PARTS LIST  
86"/90" LIFT**

1	051181	HYDRAULIC CYLINDER	1
2	109101	POWER UNIT	1
3	109102	BATTERY	1
4	109104	VOLTMETER	1
5	052779	BATTERY CABLE (NEG.)	1
6	052780	BATTERY CABLE (POS.)	1
7	109150	BATTERY CHARGER	1
8	125824	HYDRAULIC HOSE	1
9	052726	REMOTE CONTROL ASS'Y	1
10	109325	SWITCH	1
11	050784	LIFT CHAIN ASS'Y	2
12	050776	ROLLER CARRIER ASS'Y	2
13	052010	FLOOR LOCK	1
14	053769	WHEEL	2
15	150024	CASTER	2
16	109117	SOLENOID	1

**HYDRAULIC CYLINDER PARTS LIST**

17	051105	CYLINDER	1
18	051138	PISTON	1
19	050006	CYLINDER CAP	1
20	220171	SEAL KIT	1

THIS DRAWING IN ALL PARTICULARS IS WESCO INDUSTRIAL PRODUCTS INC. PROPERTY. ALL RIGHTS OF DESIGN, INVENTION OR USE OF ARE RESERVED.

PRINT ISSUED

OTC. 16, 2006

WESCO MANUFACTURING  
ENGINEERING DEPARTMENT

REV. ECN & DATE REVISIONS APP	<b>WESCO INDUSTRIAL PRODUCTS INC.</b>		NORTH WALES PENNA. 19454	
	PART NAME		DRAWN: KL 08-07-01	
	PSFL-86-25-20S-1.5K		CHECKED: PS 08-16-01	
	TOLERANCE UNLESS OTHERWISE SPECIFIED		APP. ENGR.	
FRACTION 3 PLACE DECIMAL 2 PLACE DECIMAL		SCALE: 1" = 20"		
± 1/64 ± .005 ± .01		B- 261086 REV		
ANGULAR ± 1-1/2° SHEET 1 OF 2				
BREAK ALL SHARP EDGES AND REMOVE ALL BURRS				