

POWERED STACKERS

Features:

- Adjustable base legs available on fork models.
- Fixed platforms 24x24, 24x27, 30x32
- Reinforced frame and base.
- Double chain, lift support.
- Heavy-duty pump.
- Ergonomic "D" handles.
- 110V AC models available.

ADJUSTABLE FORK MODELS

Model: PSPL-68-2424-15S-1.5K
 Lift Height: 68"
 O.A.H: 83"
 Weight: 436
 Capacity: 1,500 lbs
 Load Center: 15"
 Platform LxW: 24" x 24"
 Base Leg ID/OD: 15"/21"

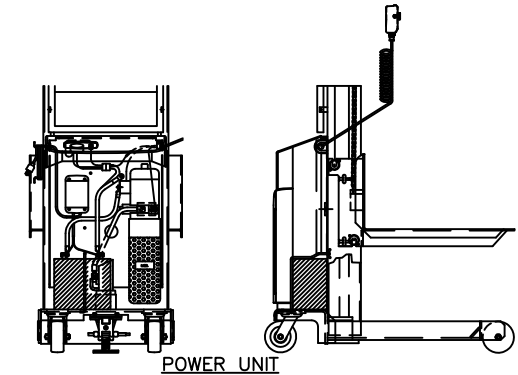
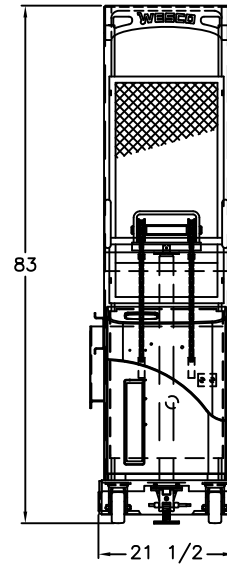
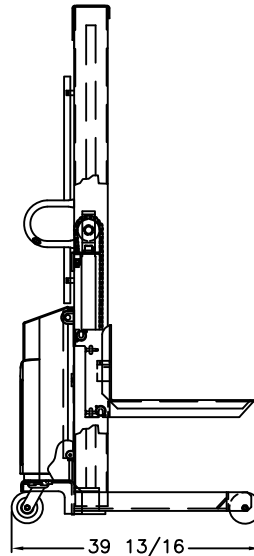
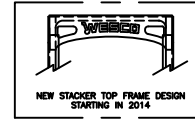
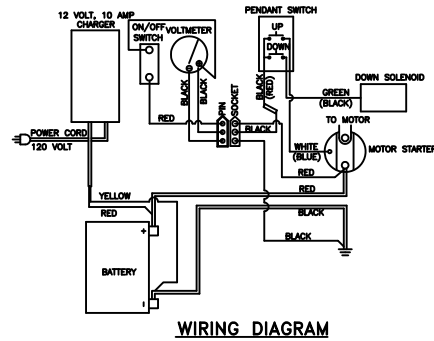

**1,500 LBS POWER STACKER PARTS LIST
64"/68" LIFT**

1	051180	HYDRAULIC CYLINDER	1
2	109101	POWER UNIT	1
3	109102	BATTERY	1
4	109104	VOLTMETER	1
5	052779	BATTERY CABLE (NEG.)	1
6	052780	BATTERY CABLE (POS.)	1
7	109150	BATTERY CHARGER	1
8	125824	HYDRAULIC HOSE	1
9	052726	REMOTE CONTROL ASSY	1
10	109325	SWITCH	1
11	050782	LIFT CHAIN ASSY	2
12	050776	ROLLER CARRIER ASSY	2
13	052010	FLOOR LOCK	1
14	053769	WHEEL	2
15	150024	CASTER	2
16	109117	SOLENOID	1

HYDRAULIC CYLINDER PARTS LIST

17	051073	CYLINDER	1
18	051044	PISTON	1
19	050006	CYLINDER CAP	1
20	220171	SEAL KIT	1

THIS DRAWING IN ALL PARTICULARS IS WESCO INDUSTRIAL PRODUCTS, LLC PROPERTY. ALL RIGHTS OF DESIGN, INVENTION OR USE OF ARE RESERVED.

PRINT ISSUED

OCT 02, 2018

WESCO MANUFACTURING
ENGINEERING DEPARTMENT

REV.	APP	WESCO INDUSTRIAL PRODUCTS, LLC			
	E	NORTH WALES		PENNA. 19454	
	C	PART NAME	PSPL-68-2424-15S-1.5K		DRAWN: KL 08-07-01
	N	REVISIONS			CHECKED: PS 08-16-01
	D	TOLERANCE UNLESS OTHERWISE SPECIFIED			APP. ENGR.
		FRACTION	3 PLACE DECIMAL	2 PLACE DECIMAL	SCALE: 1" = 20"
		± 1/64	± .005	± .01	
		ANGULAR ± 1-1/2°	SHEET 1 OF 2		
		BREAK ALL SHARP EDGES AND REMOVE ALL BURRS			B-261075