

HYDRAULIC POST TABLE - HT-60-3248

APPROX WEIGHT: 548.04 lbs.
DOES NOT INCLUDE WEIGHT OF POWER OR PACKAGING!!!

*** ANY ADDITIONS, DELETIONS, OR OMISSIONS MUST BE CORRECTED ON THIS DRAWING AS THIS DRAWING WILL BE CONSIDERED ALL INCLUSIVE ***

ALL GRAPHICS PROVIDED ARE FOR REFERENCE ONLY. IF CERTAIN DIMENSIONS ARE CRITICAL PLEASE VERIFY THOSE DIMENSIONS WITH YOUR SALESPERSON

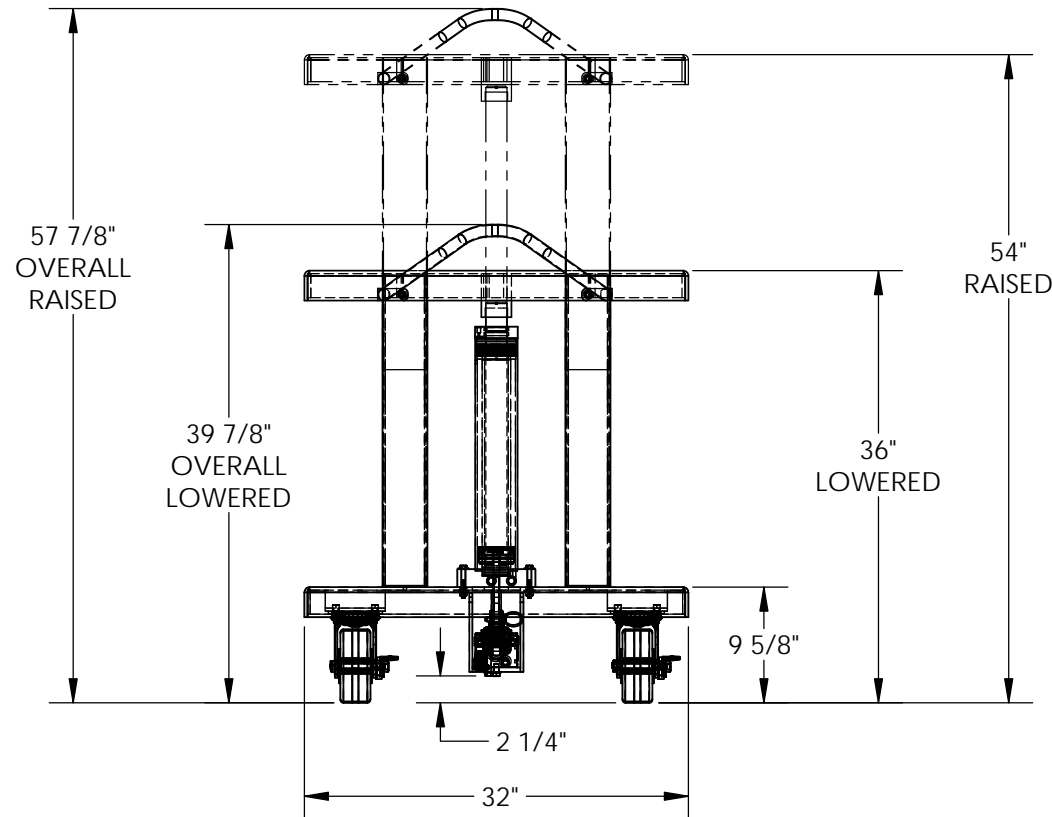
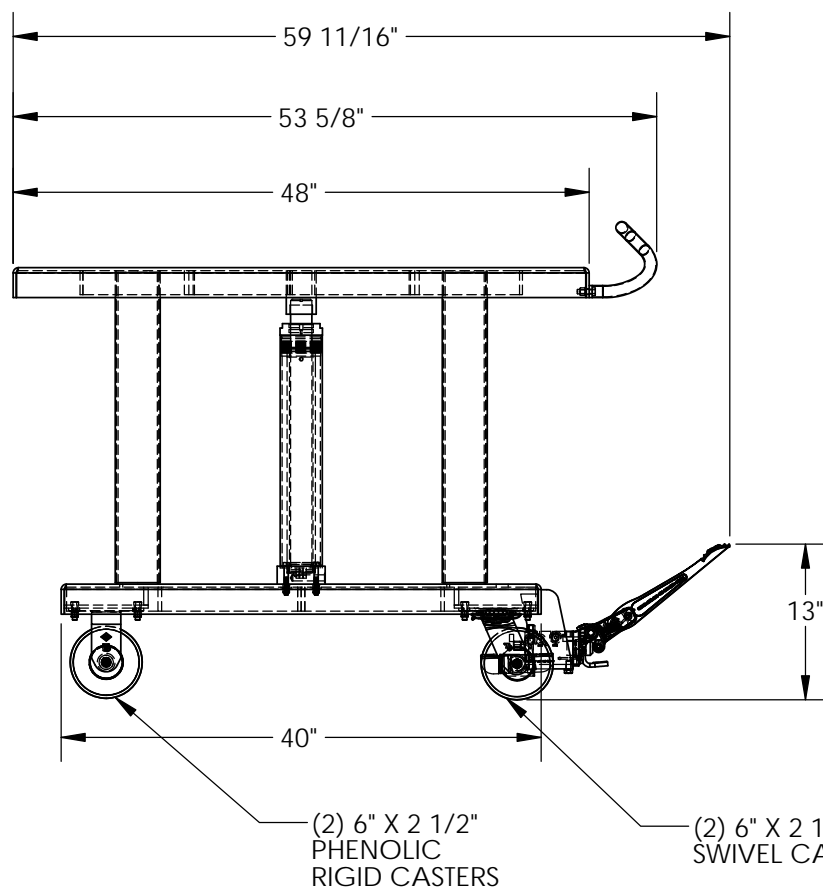

DIMENSION TOLERANCE ± 1/4"

HYDRAULIC HOSES NOT SHOWN

STANDARD FEATURES

- MODEL NUMBER IS HT-60-3248
- CAPACITY IS 6,000 LBS.
- OVERALL WIDTH IS 32"
- USABLE WIDTH IS 32"
- OVERALL LENGTH IS 59 11/16"
- USABLE LENGTH IS 48"
- RAISED HEIGHT IS 54"
- LOWERED HEIGHT IS 36"
- OVERALL RAISED HEIGHT IS 57 7/8"
- OVERALL LOWERED HEIGHT IS 39 7/8"
- (2) PHENOLIC RIGID CASTERS
- (2) PHENOLIC SWIVEL CASTERS WITH BRAKES

SPECIAL FEATURES

NONE

APPROVAL

I, THE UNDERSIGNED, AGREE THAT THE PRODUCT AS REPRESENTED SATISFIES DESIGN AND DIMENSION REQUIREMENTS. I ALSO ACKNOWLEDGE MY DUTY TO CONFIRM PRODUCT AND INSTALLATION COMPLIANCE WITH ALL APPLICABLE FEDERAL, STATE AND LOCAL REGULATIONS AND STANDARDS.

ANY MODIFIED UNITS ARE NON-RETURNABLE

[] As drawn [] As marked

Signed: _____ Date: _____

Printed Name: _____

LEAD TIME WILL START UPON RECEIPT OF SIGNED APPROVAL DRAWING

FOR INTERNAL USE ONLY PROJECT SIGN OFF	
SALES	
ENG.	
FAB.	
POWER	

DISTRIBUTOR'S NAME:		P.O.#
VESTIL MANUFACTURING		X
W.O.#		X
DRAWN BY: TAW	DATE: 03/25/2016	SALES: X
REFERENCE: X	SCALE: 1:16	FILE NAME:
QUOTED LEAD TIME: X	QUOTE # X	21-007-048