

# HYDRAULIC POST TABLE - HT-60-4048

APPROX WEIGHT: 602.86 lbs.  
DOES NOT INCLUDE WEIGHT OF POWER OR PACKAGING!!!

\*\*\* ANY ADDITIONS, DELETIONS, OR OMISSIONS MUST BE CORRECTED ON THIS DRAWING AS THIS DRAWING WILL BE CONSIDERED ALL INCLUSIVE \*\*\*

ALL GRAPHICS PROVIDED ARE FOR REFERENCE ONLY. IF CERTAIN DIMENSIONS ARE CRITICAL PLEASE VERIFY THOSE DIMENSIONS WITH YOUR SALESPERSON

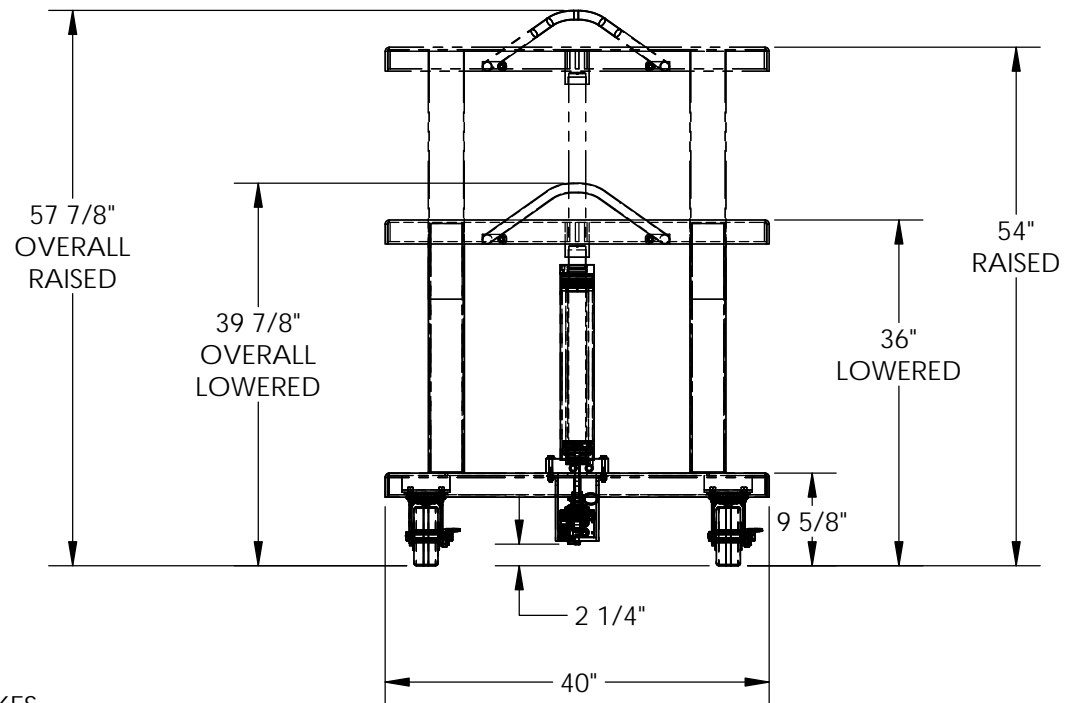
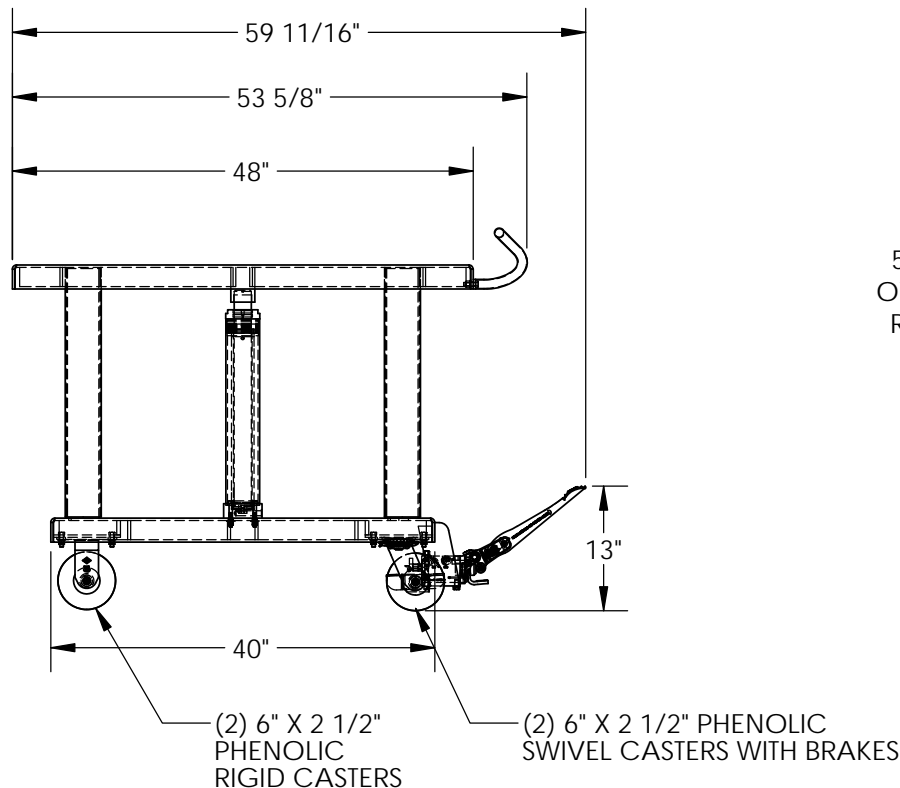

DIMENSION TOLERANCE ± 1/4"

HYDRAULIC HOSES NOT SHOWN

## STANDARD FEATURES

- MODEL NUMBER IS HT-60-4048
- CAPACITY IS 6,000 LBS.
- OVERALL WIDTH IS 40"
- USABLE WIDTH IS 40"
- OVERALL LENGTH IS 59 11/16"
- USABLE LENGTH IS 48"
- RAISED HEIGHT IS 54"
- LOWERED HEIGHT IS 36"
- OVERALL RAISED HEIGHT IS 57 7/8"
- OVERALL LOWERED HEIGHT IS 39 7/8"
- (2) PHENOLIC RIGID CASTERS
- (2) PHENOLIC SWIVEL CASTERS WITH BRAKES

## SPECIAL FEATURES

NONE

**APPROVAL**

I, THE UNDERSIGNED, AGREE THAT THE PRODUCT AS REPRESENTED SATISFIES DESIGN AND DIMENSION REQUIREMENTS. I ALSO ACKNOWLEDGE MY DUTY TO CONFIRM PRODUCT AND INSTALLATION COMPLIANCE WITH ALL APPLICABLE FEDERAL, STATE AND LOCAL REGULATIONS AND STANDARDS.

**ANY MODIFIED UNITS ARE NON-RETURNABLE**

[ ] As drawn      [ ] As marked

Signed: \_\_\_\_\_ Date: \_\_\_\_\_

Printed Name: \_\_\_\_\_

*LEAD TIME WILL START UPON RECEIPT OF SIGNED APPROVAL DRAWING*

FOR INTERNAL USE ONLY PROJECT SIGN OFF	
SALES	
ENG.	
FAB.	
POWER	

DISTRIBUTOR'S NAME:		P.O.#
VESTIL MANUFACTURING		X
DRAWN BY: TAW		DATE: 4/14/2016
REFERENCE: X		SCALE: 1:20
QUOTED LEAD TIME: X		QUOTE # X
		W.O.# X
		SALES: X
		FILE NAME: 21-007-113