

# HYDRAULIC POST TABLE HT-20-2436-DC

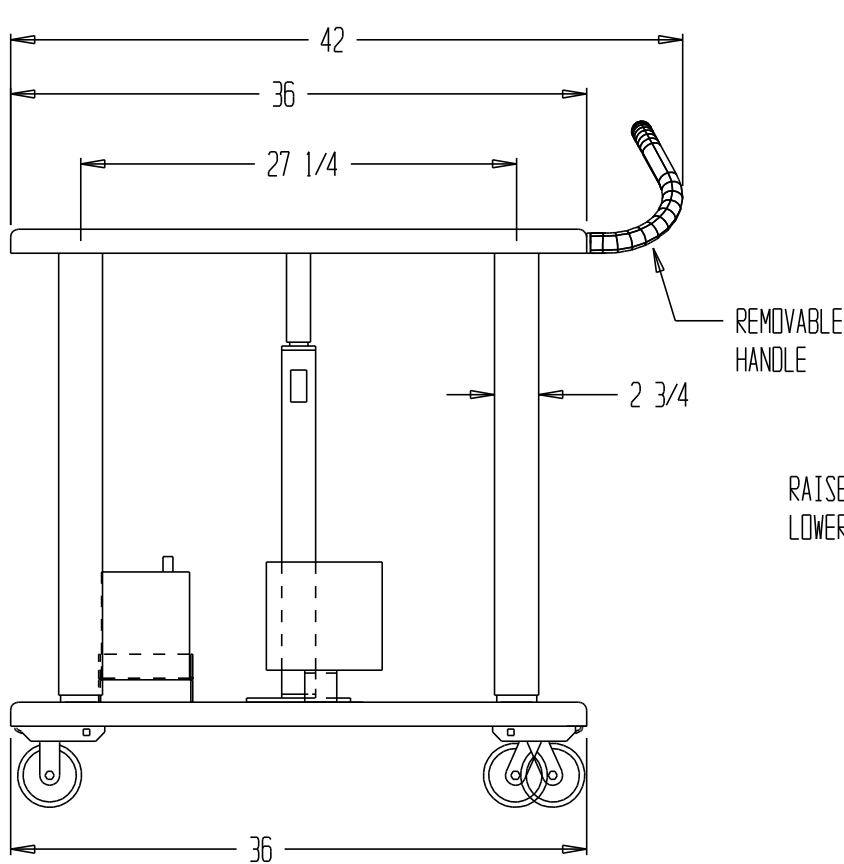

RAISED HEIGHT: 54"  
LOWERED HEIGHT: 36"

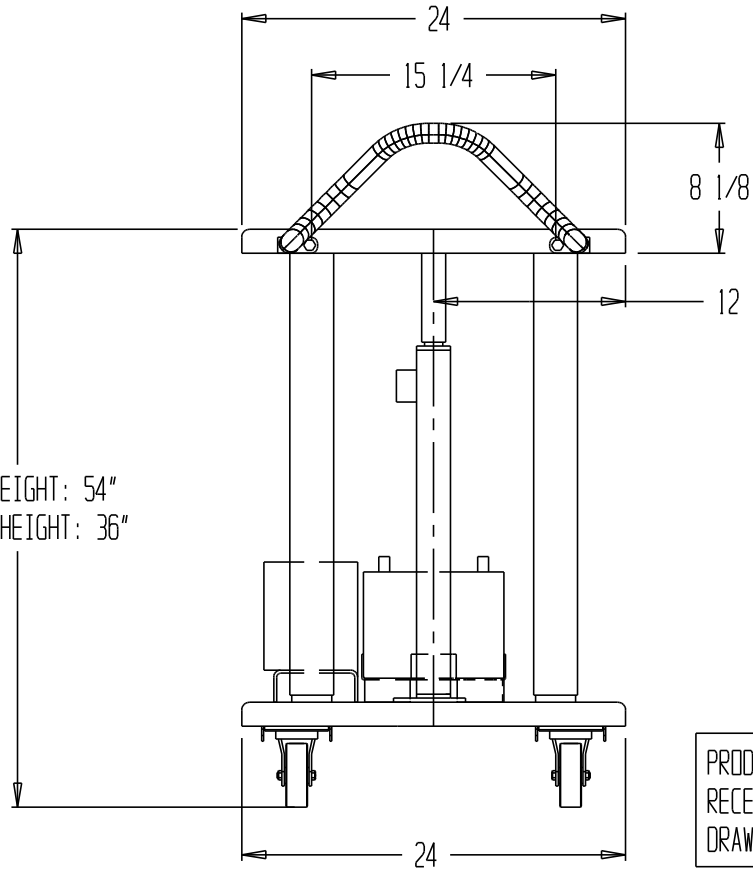

PRODUCTION WILL START UPON  
RECEIPT OF SIGNED APPROVAL  
DRAWING

## STANDARD FEATURES

- MODEL NUMBER: HT-20-2436-DC
- CAPACITY: 2,000 LBS.
- PLATFORM SIZE: 24" W x 36" L
- RAISED HEIGHT: 54"
- LOWERED HEIGHT: 36"
- FOUR POST DESIGN
- DC POWER OPERATION
- CASTERS ARE 4 x 2  
(2 SWIVEL, 2 RIGID)

## SPECIAL FEATURES

NONE

\*\*SPECIAL UNITS ARE NON-RETURNABLE  
\*AVAILABLE AT ADDITIONAL COSTS

## APPROVAL

I, the undersigned, hereby approve this print  
[ ] As drawn [ ] As marked

This includes my approval of design & dimensions.

Signed: \_\_\_\_\_

Date: \_\_\_\_\_

DISTRIBUTOR'S NAME: <b>T &amp; S EQUIPMENT</b>		P.O.#: _
DRAWN BY: EJ		W.O.#: _
DATE: 9/20/04		SALES: _
REFERENCE: -	DRWG./FILE NAME: 21-007-049	scale: 1:12