

TRIPLE ELBOW GUARD - TEGC-24-36-2 WITH CENTER SUPPORT

APPROX WEIGHT: 16.53 lbs.
DOES NOT INCLUDE WEIGHT OF POWER OR PACKAGING!!!

ANY ADDITIONS, DELETIONS, OR OMISSIONS MUST BE CORRECTED ON THIS DRAWING AS THIS DRAWING WILL BE CONSIDERED ALL INCLUSIVE

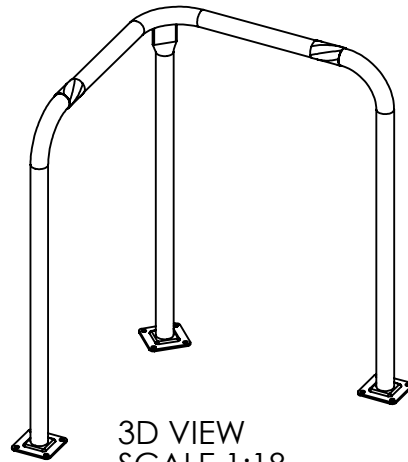
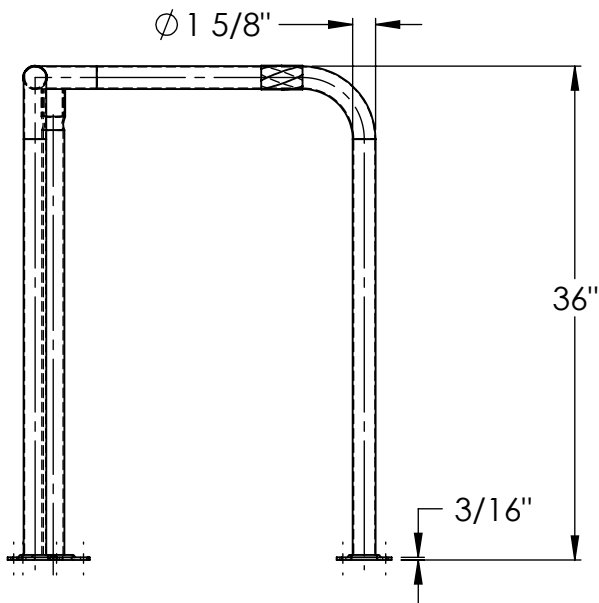
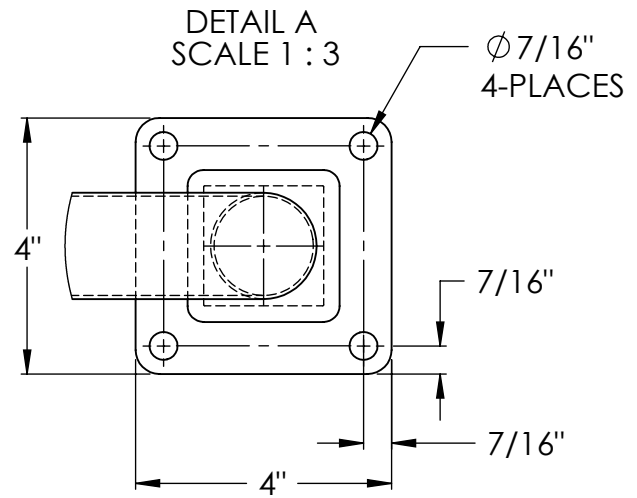
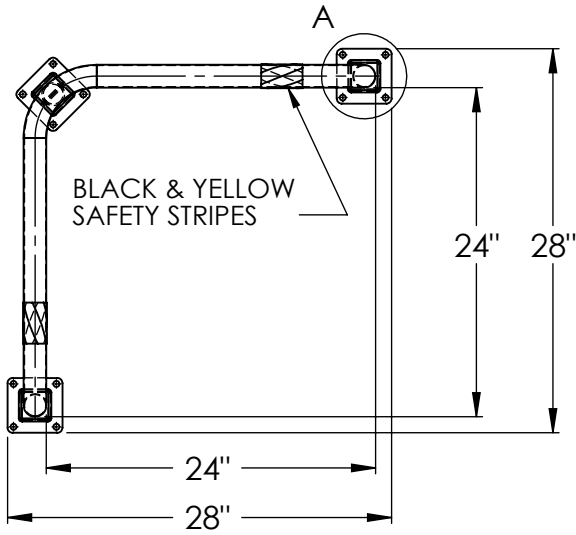

FOR INTERNAL USE ONLY PROJECT SIGN OFF	
SALES	
ENG.	
FAB.	
POWER	

DIMENSION TOLERANCE ± 1/4"

ALL GRAPHICS PROVIDED ARE FOR REFERENCE ONLY. IF CERTAIN DIMENSIONS ARE CRITICAL PLEASE VERIFY THOSE DIMENSIONS WITH YOUR SALESPERSON

STANDARD FEATURES

- MODEL NUMBER IS TEGC-24-36-2
- GUARD LENGTH: 24"
- GUARD DEPTH: 24"
- OVERALL LENGTH: 28"
- OVERALL DEPTH: 28"
- OVERALL HEIGHT: 36"
- PIPE DIAMETER: 1 5/8"
- (2) 4" x 4" MOUNTING PLATES
- BLACK AND YELLOW SAFETY STRIPES
- TOUGH BAKED IN POWDER COATED YELLOW FINISH
- ALL STEEL CONSTRUCTION (ASTM A-36 MIN.) WITH WELDING TO MEET AWS
- WARNING: CHECK APPLICABLE STATE & LOCAL LAWS FOR YOUR AREA

SPECIAL FEATURES

NONE

APPROVAL	I, THE UNDERSIGNED, AGREE THAT THE PRODUCT AS REPRESENTED SATISFIES DESIGN AND DIMENSION REQUIREMENTS. I ALSO ACKNOWLEDGE MY DUTY TO CONFIRM PRODUCT AND INSTALLATION COMPLIANCE WITH ALL APPLICABLE FEDERAL, STATE AND LOCAL REGULATIONS AND STANDARDS.	
	ANY MODIFIED UNITS ARE NON-RETURNABLE	
	[] As drawn [] As marked	
	Signed: _____ Date: _____	
Printed Name: _____		
<i>LEAD TIME WILL START UPON RECEIPT OF SIGNED APPROVAL DRAWING</i>		

DISTRIBUTOR'S NAME:		P.O.#
VESTIL MANUFACTURING		X
		W.O.#
DRAWN BY: SR		X
DATE: 07/23/08		SALES: X
REFERENCE: X	SCALE: 1:14	FILE NAME:
QUOTED LEAD TIME: X	QUOTE # X	23-007-247