

# EDGE-O-DOCKLEVELER - PP-2572

APPROX WEIGHT: 600.49 lbs.  
DOES NOT INCLUDE WEIGHT OF POWER OR PACKAGING!!!

\*\*\* ANY ADDITIONS, DELETIONS, OR OMISSIONS MUST BE CORRECTED ON THIS DRAWING AS THIS DRAWING WILL BE CONSIDERED ALL INCLUSIVE \*\*\*

ALL GRAPHICS PROVIDED ARE FOR REFERENCE ONLY. IF CERTAIN DIMENSIONS ARE CRITICAL PLEASE VERIFY THOSE DIMENSIONS WITH YOUR SALESPERSON

\*\*HAND PUMP NOT SHOWN IN FRONT OR RIGHT VIEW\*\*

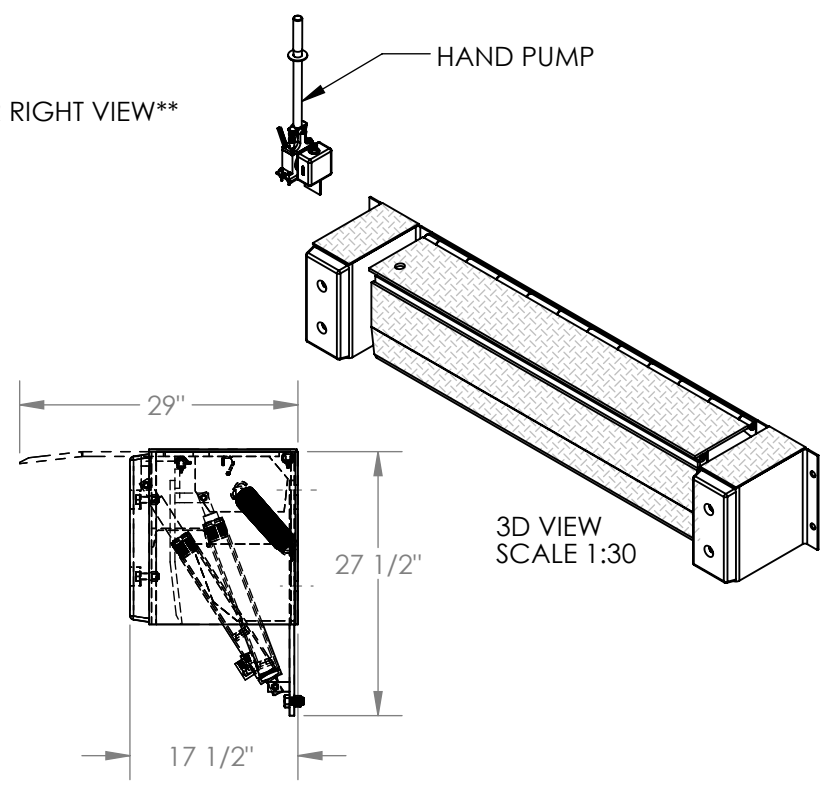
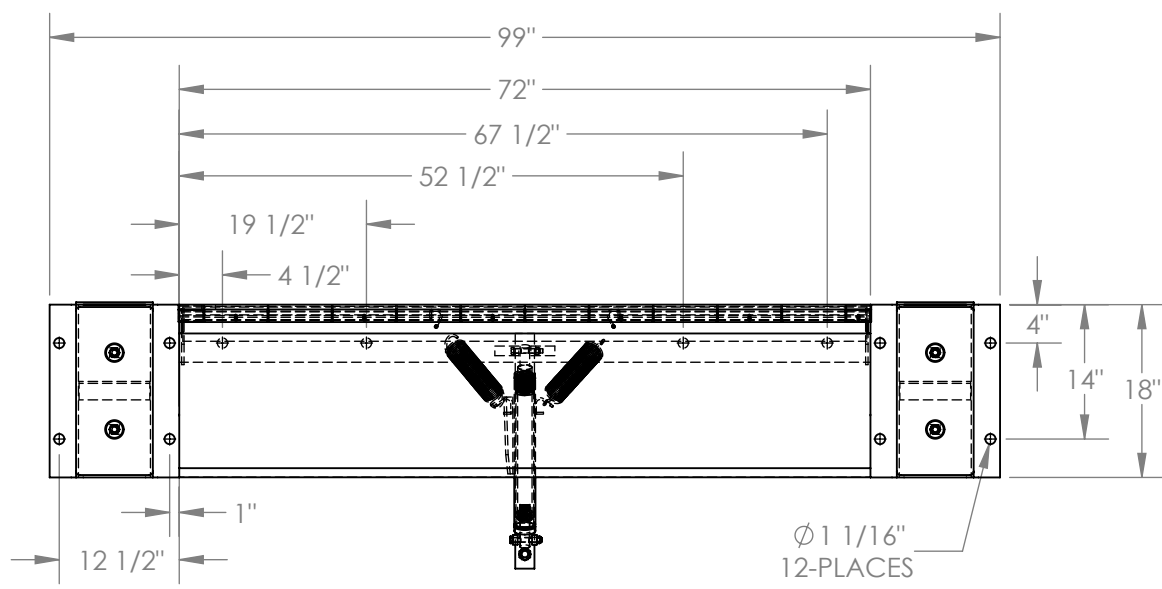

## STANDARD FEATURES

- MODEL NUMBER IS PP-2572
- OVERALL WIDTH IS 99"
- DECK WIDTH IS 72"
- OVERALL DEPTH WITH RAMP OUT IS 29"
- BUMPER PROJECTION IS 17 1/2"
- UNIFORM CAPACITY IS 25,000 LBS.
- 5" ABOVE / 5" BELOW SERVICE RANGE
- HYDRAULIC HAND PUMP OPERATION
- RECOMMENDED FOR DOCKS AT LEAST 48" HIGH.
- INCLUDES HAND PUMP, WALL-MOUNT BRACKET, CYLINDER, HYDRAULIC LINES AND OIL.
- TREADPLATE RAMP & DECK CONSTRUCTION

## SPECIAL FEATURES

NONE

DIMENSION TOLERANCE ± 1/4"

<b>APPROVAL</b>	I, THE UNDERSIGNED, AGREE THAT THE PRODUCT AS REPRESENTED SATISFIES DESIGN AND DIMENSION REQUIREMENTS. I ALSO ACKNOWLEDGE MY DUTY TO CONFIRM PRODUCT AND INSTALLATION COMPLIANCE WITH ALL APPLICABLE FEDERAL, STATE AND LOCAL REGULATIONS AND STANDARDS.	
	<b>ANY MODIFIED UNITS ARE NON-RETURNABLE</b>	
	[ ] As drawn      [ ] As marked	
	Signed: _____	Date: _____
Printed Name: _____		
<b>LEAD TIME WILL START UPON RECEIPT OF SIGNED APPROVAL DRAWING</b>		

FOR INTERNAL USE ONLY PROJECT SIGN OFF	
SALES	
ENG.	
FAB.	
POWER	

DISTRIBUTOR'S NAME:		P.O.#
VESTIL MANUFACTURING		X
DRAWN BY: M.WILSON		W.O.#
DATE: 12/19/2012		X
REFERENCE: X	SCALE: 1:20	SALES: X
QUOTED LEAD TIME: X	QUOTE #	FILE NAME:
	X	06-007-005