

For More Information: 866-333-0728



Logitrans
lifting performance



QUARTER PALLET TRUCKS

LQHM440, LQHM660, DLQ440



LogiQ 440

LogiQ 660

DLQ440 (double quarter pallet lifter)

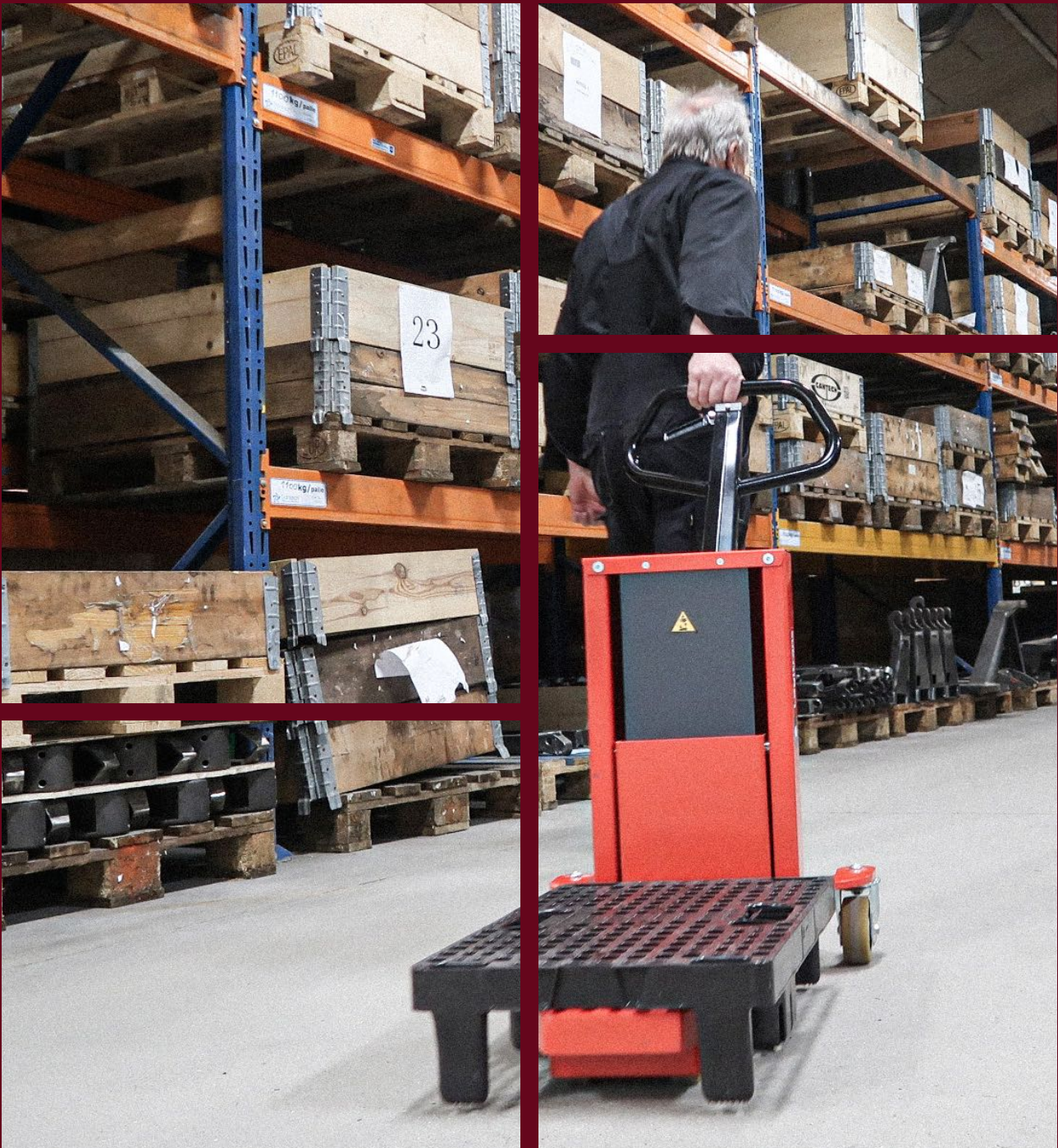

Elegant solution for quarter pallet transportation

Quarter pallet lifters are indispensable equipment for customers, who handle quarter pallets in e.g. supermarkets, storage and packaging areas, and gas stations.

The pallet lifters are small, compact and very easy to operate. The handles have ergonomically correct gripping

angles, which ensures the operator a relaxed hold. The wheels ensure a comfortable and noiseless transport - and are gentle to the fine floor and flagstone layer in the customer areas.

Quarter pallet lifters are oftentimes used to move around display pallets in crowded and

confined areas (LogiQ 440), and to grab quarter pallets from EUR pallets in storage areas (LogiQ 660).

If you need to take two quarter pallets at the same time - or to reach the last pallet at the far end of a EUR pallet, the DLQ 440 is your preferred helper.

Ergonomically correct handle

CE marking

Hydraulic pump with quick lift

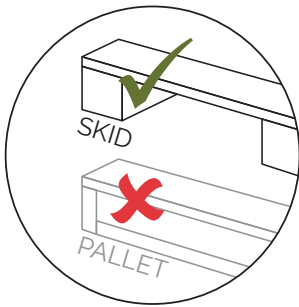

Foot protection



Vulkollan wheels ensure a comfortable and noiseless transport



Parking brake

LogiQ 440

The LogiQ 440 is the ideal solution if you need to move around quarter pallets in customer areas, such as supermarkets, grocery stores, gas stations etc.

The small, manual pallet lifter is easy to operate in crowded and compact areas. The noiseless wheels and compact design allow you to move around in customer areas without disturbing or bumping into the surroundings.

The handle has an ergonomic design for the operator and it only takes one stroke to lift the pallets from the floor. In addition, it has foot protection on the steering wheels.

The capacity is 440 lbs.

We use a special oil for all products, which is tested in cold atmospheres down to at least -10 degrees C.



LogiQ 660

The LogiQ 660 is suitable for storage and packaging areas, and other situations, where you need to take a quarter pallet from a EUR pallet and move it to a desired location.

This manual quarter pallet lifter has a hydraulic pump, which minimizes the number of pumping strokes needed to lift the pallet. This protects the operator from unnecessary physical strain. It only takes half a pump stroke to lift a

In addition, it is equipped with a parking brake and foot protection on the steering wheels.

The capacity is 660 lbs.

We use a special oil for all products, which is tested in cold atmospheres down to at least -10 degrees C.





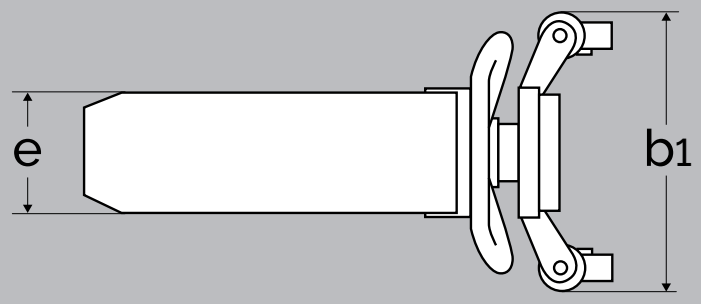
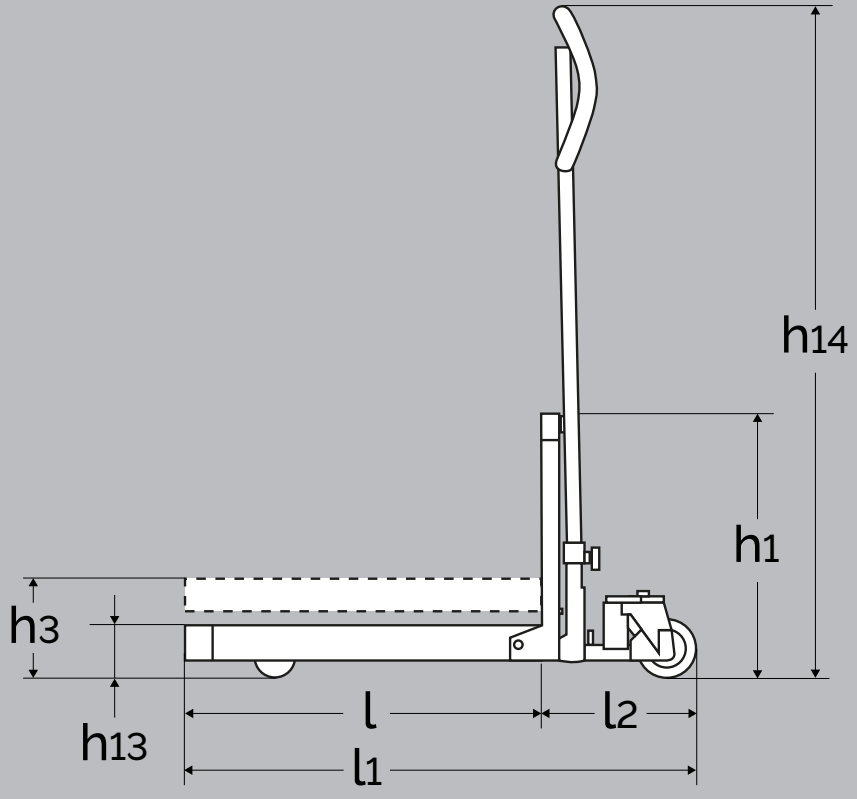

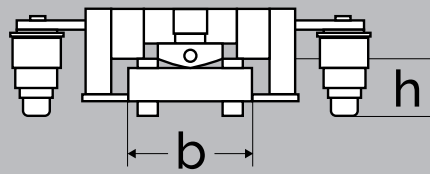
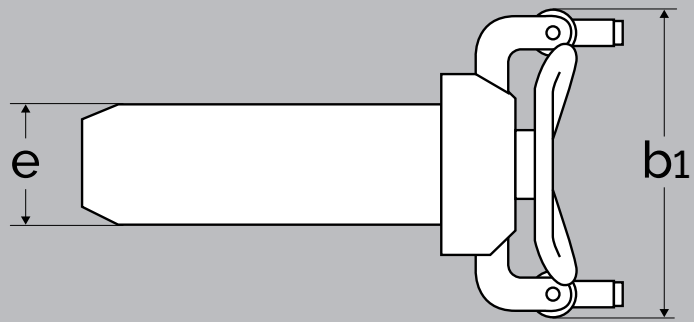
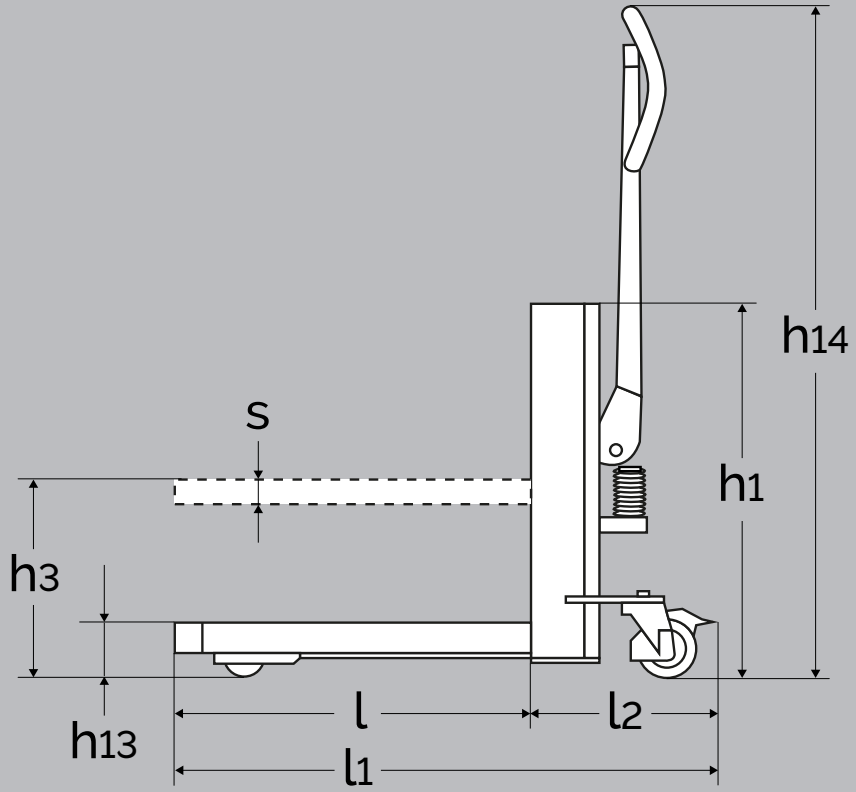

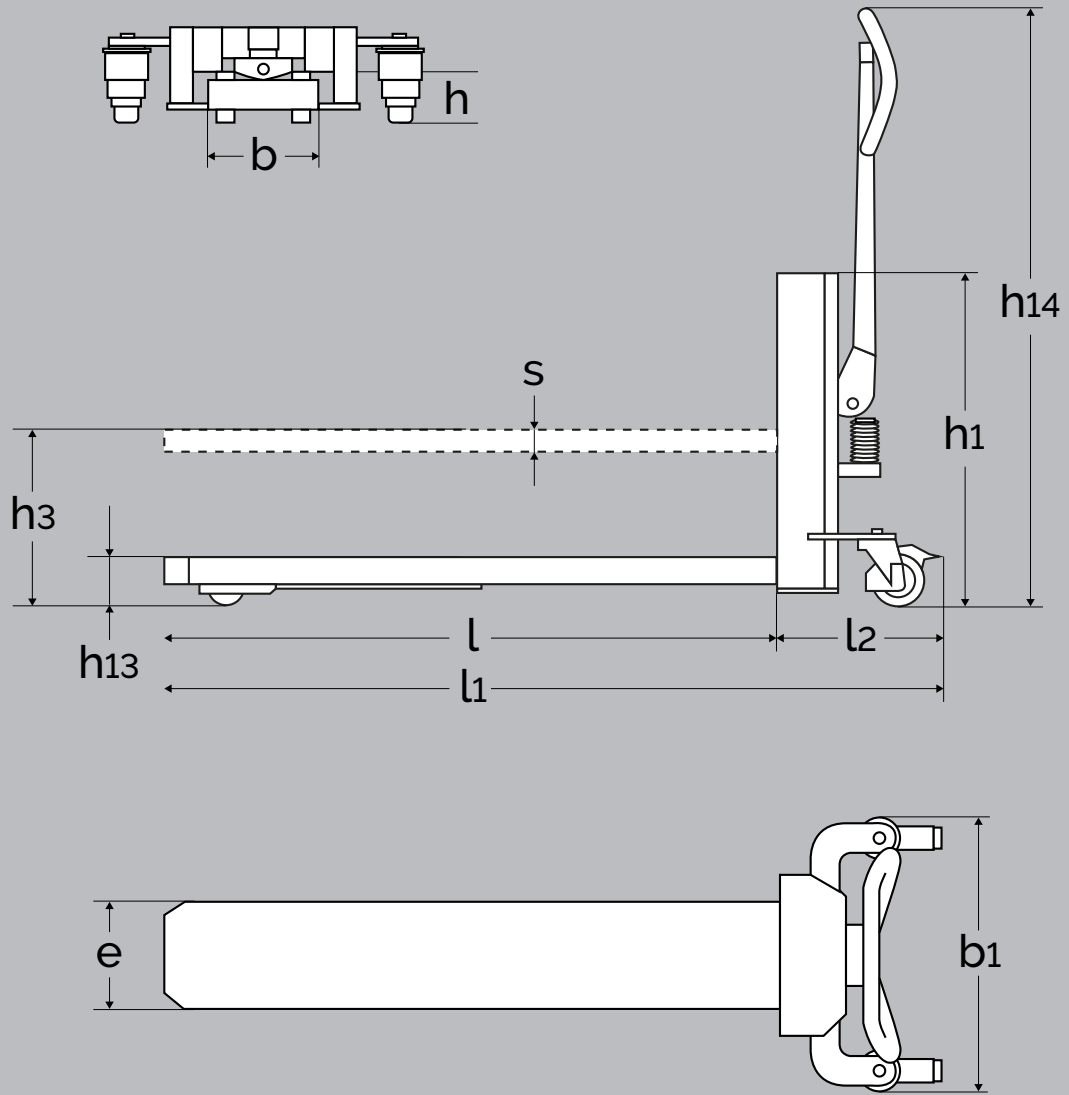

PRODUCT (measured in inch)	LQHM 440	LQHM 660	DLQ 440
-------------------------------	----------	----------	---------

Capacity in lbs		440 lbs	660 lbs	440 lbs
Lifting height	h_3	4.5	12.4	12.4
Fork length	l	23.5	23.5	47.2
Chassis height without fork	h		3.25	24.6
Overall height	h_1	18.5	24.6	3.2
Chassis span	b		7.2	11.75
Overall width	b_1	18	20	59.1
Length without forks	l_2	10.25	11.75	7.2
Overall length	l_1	33.9	35.5	59.1
Lowered height	h_{13}	3.25	3.25	3.25
Fork width	e	8	8	8
Fork thickness	s		1.75	1.75
Overall height with handle	h_{14}	40.95	46	46
Weight		49 lbs	104 lbs	

Distributed by:
 Custom Equipment Company
 866-333-0728
 tom@custommhs.com
 www.custommhs.com